



Installation Guide

Three Phase System with SetApp Configuration

For North America

Version 1.2

Disclaimers

Important Notice

Copyright © SolarEdge Inc. All rights reserved.

No part of this document may be reproduced, stored in a retrieval system or transmitted, in any form or by any means, electronic, mechanical, photographic, magnetic or otherwise, without the prior written permission of SolarEdge Inc.

The material furnished in this document is believed to be accurate and reliable. However, SolarEdge assumes no responsibility for the use of this material. SolarEdge reserves the right to make changes to the material at any time and without notice. You may refer to the SolarEdge web site (<https://www.solaredge.com/us/>) for the most updated version.

All company and brand products and service names are trademarks or registered trademarks of their respective holders.

Patent marking notice: see <https://www.solaredge.com/us/patent>

The general terms and conditions of delivery of SolarEdge shall apply.

The content of these documents is continually reviewed and amended, where necessary. However, discrepancies cannot be excluded. No guarantee is made for the completeness of these documents.

The images contained in this document are for illustrative purposes only and may vary depending on product models.

FCC Compliance

This equipment has been tested and found to comply with the limits for a Class B digital device, pursuant to part 15 of the FCC Rules. These limits are designed to provide reasonable protection against harmful interference in a residential installation. This equipment generates, uses and can radiate radio frequency energy and, if not installed and used in accordance with the instructions, may cause harmful interference to radio communications. However, there is no guarantee that interference will not occur in a particular installation. If this equipment does cause harmful interference to radio or television reception, which can be determined by turning the equipment off and on, you are encouraged to try to correct the interference by one or more of the following measures:

- Reorient or relocate the receiving antenna.
- Increase the separation between the equipment and the receiver.
- Connect the equipment into an outlet on a circuit different from that to which the receiver is connected.
- Consult the dealer or an experienced radio/TV technician for help.

Changes or modifications not expressly approved by the party responsible for compliance may void the user's authority to operate the equipment.

Support and Contact Information

If you have technical problems concerning SolarEdge products, please contact us:

Support Center: <https://www.solaredge.com/service/support>

USA and Canada: 1 510 498 3200

Worldwide: +972 073 2403118

Fax: +1 (530) 273-2769

Email: ussupport@solaredge.com.

Support Center: <https://www.solaredge.com/us/service/support>

Before contact, make sure to have the following information at hand:

- Model and serial number of the product in question.
- The error indicated on the Inverter SetApp mobile application or on the monitoring platform or by the LEDs, if there is such an indication.
- System configuration information, including the type and number of modules connected and the number and length of strings.
- The communication method to the SolarEdge server, if the site is connected.
- The inverter software version as appears in the status screen.

Revision History

Version 1.2 (Feb. 2019)

- Added appendix 'Determining the Circuit Breaker Size' and paragraph referencing to it, in the 'Grid Connection Guidelines' section.
- Updated guidelines for use of extension cables in power optimizer installation.
- Torque for plastic cover screws 10.3 N*m/ 7.5 lb-ft.
- In Specifications removed 'Recommended OCPD size per grid' table.
- Added Proposition 65 warning (for California).

Version 1.1 (Dec. 2018)

- Updated communication options and menus

Version 1.0 (Sept. 2018)

Initial release

Contents

Disclaimers	1
Important Notice	1
FCC Compliance	2
Support and Contact Information	3
Revision History	4
Contents	5
HANDLING AND SAFETY INSTRUCTIONS	7
Safety Symbols Information	7
IMPORTANT SAFETY INSTRUCTIONS	8
Chapter 1: Introducing the SolarEdge Power Harvesting System	12
Power Optimizer	12
Inverter with Safety Switch	13
Monitoring Platform	13
Supported AC Grids	14
Installation Procedure	14
Installation Equipment List	14
Inverter Transport and Storage	15
Chapter 2: Installing the Power Optimizers	16
Safety	16
Package Contents	18
Installation Guidelines	18
Step 1: Mounting and Grounding the Power Optimizers	22
Step 2: Connecting a PV Module to a Power Optimizer	25
Step 3: Connecting Power Optimizers in Strings	25
Step 4: Verifying Proper Power Optimizer Connection	26
Chapter 3: Installing the Inverter	28
Inverter Package Contents	28
Identifying the Inverter	28
Inverter Interfaces	28
Opening Conduit Drill Guides	34
Mounting the Inverter	35
Chapter 4: Connecting the AC and the Strings to the Safety Switch	41
Grid Connection Guidelines	42
Setting the Inverter to Support 208V 3-wire Grid	43
Connecting the AC Grid to the Safety Switch	44
Connecting the Strings to the Safety Switch	48
Chapter 5: Activating, Commissioning and Configuring the System Using the Inverter SetApp	51

Step 1: Activating the Installation	51
Step 2: Commissioning and Configuring the Installation	52
Step 3: Verifying Proper Activation and Commissioning	56
Viewing System Status	57
Reporting and Monitoring Installation Data	63
Chapter 6: Setting Up Communication	66
Communication Options	66
Communication Connectors	68
Removing the Inverter Cover	69
Creating an Ethernet (LAN) Connection	69
Creating an RS485 Bus Connection	73
Verifying the Connection	77
Appendix A: Errors and Troubleshooting	79
Identifying Errors	79
Troubleshooting Communication	81
Power Optimizer Troubleshooting	82
Appendix B: Mechanical Specifications	84
Appendix C: External Fan Maintenance and Replacement	85
Fan Maintenance	85
External Fan Replacement	85
Appendix D: Replacing and Adding System Components	88
Replacing an Inverter	88
Replacing the Safety Switch	89
Adding, Removing, or Replacing Power Optimizers	92
Appendix E: Determining the Circuit Breaker Size	93
Revision History	93
Introduction	93
Using Transformers in Commercial Three Phase Inverter Installations	93
Determining the Size of an Inverter Circuit Breaker	95
Technical Specifications - Three Phase Inverters (North America)	97
Default Trip Limits and Times According to IEEE1547	99
Safety Switch	99

HANDLING AND SAFETY INSTRUCTIONS

During installation, testing and inspection, adherence to all the handling and safety instructions is mandatory. **Failure to do so may result in injury or loss of life and damage to the equipment.**

Safety Symbols Information

The following safety symbols are used in this document. Familiarize yourself with the symbols and their meaning before installing or operating the system.

WARNING!

Denotes a hazard. It calls attention to a procedure that, if not correctly performed or adhered to, could result in **injury or loss of life**. Do not proceed beyond a warning note until the indicated conditions are fully understood and met.



AVERTISSEMENT!

Dénote un risque: il attire l'attention sur une opération qui, si elle n'est pas faite ou suivie correctement, pourrait causer des blessures ou un danger de mort. Ne pas dépasser une telle note avant que les conditions requises soient totalement comprises et accomplies.

CAUTION!

Denotes a hazard. It calls attention to a procedure that, if not correctly performed or adhered to, could result in **damage or destruction of the product**. Do not proceed beyond a caution sign until the indicated conditions are fully understood and met.



ATTENTION!

Dénote un risque: il attire l'attention sur une opération qui, si elle n'est pas faite ou suivie correctement, pourrait causer un dommage ou destruction de l'équipement. Ne pas dépasser une telle note avant que les conditions requises soient totalement comprises et accomplies.



NOTE

Denotes additional information about the current subject.



IMPORTANT SAFETY FEATURE

Denotes information about safety issues.

IMPORTANT SAFETY INSTRUCTIONS

SAVE THESE INSTRUCTIONS

CONSIGNES DE SÉCURITÉ IMPORTANTES

CONSERVEZ CES INSTRUCTIONS

WARNING!



The inverter cover must be opened only after switching the inverter ON/OFF/P switch located at the bottom of the inverter to OFF. This disables the DC voltage inside the inverter. Wait five minutes before opening the cover. Otherwise, there is a risk of electric shock from energy stored in the capacitors.

AVERTISSEMENT!

Ne pas ouvrir le couvercle de l'onduleur avant d'avoir coupé l'interrupteur situé en dessous de l'onduleur. Cela supprime les tensions CC et CA de l'onduleur. Attendre cinq minutes avant d'ouvrir le couvercle. Sinon, il y a un risque de choc électrique provenant de l'énergie stockée dans le condensateur.



P = Program/Pair
1 = ON
0 = OFF

WARNING!



Before operating the inverter, ensure that the inverter is grounded properly. This product must be connected to a grounded, metal, permanent wiring system, or an equipment-grounding conductor must be run with the circuit conductors and connected to the equipment grounding terminal or lead on the product.

AVERTISSEMENT!

Avant d'utiliser l'onduleur monophasé, assurez-vous que l'onduleur est correctement mis à la terre. Ce produit doit être raccordé à un système de câblage fixe, métallique, l'équipement-le conducteur de mise à la terre doit être exécuté avec les conducteurs de circuit et raccordé à l'équipement borne de mise à la terre ou de plomb sur le produit.

WARNING!



Opening the inverter and repairing or testing under power must be performed only by qualified service personnel familiar with this inverter.

AVERTISSEMENT!

L'unité ne doit être ouverte que par un technicien qualifié dans le cadre de l'installation et de la maintenance.

WARNING!

The Safety Switch meets all requirements for a code-compliant installation of this system. The DC Disconnect Switch disconnects both the positive and negative conductors.

AVERTISSEMENT!

Le sectionneur externe (inclus) répond aux exigences de conformité pour l'installation de ce système. Le coupeur CC ouvre les conducteurs positifs et négatifs.

WARNING!

The inverter input and output circuits are isolated from the enclosure. This system does not include an isolation transformer and should be installed with an ungrounded PV array in accordance with the requirements of NEC Articles 690.35 and 690.43 National Electric Code, ANSI/NFPA 70, 2011 (and Canadian Electrical Code, Part I, for installations in Canada).

Equipment grounding is the responsibility of the installer and must be performed in accordance with all applicable Local and National Codes.

AVERTISSEMENT!

Les circuits d'entrée et de sortie de l'onduleur sont isolés de l'enveloppe. Ce système n'inclut pas d'isolation galvanique (transformateur) et devra être installé sans mise à la terre du champ PV et en accord avec les articles 690.35 et 690.43 du National Electric Code (NEC), ANSI/NFPA 70, 2011 (et du Code Electrique Canadien, Partie 1, pour les installations faites au Canada). La mise à la terre des équipements est la responsabilité de l'installateur et doit être faite en accord avec les toutes les règles locales et nationales applicables.

WARNING!

Three phase 9,10, 20 kW inverter must be connected to a dedicated AC branch circuit with a maximum Overcurrent Protection Device (OCPD) of 40A.

Three phase 14.4, 33.3 kW inverters must be connected only to a dedicated AC branch circuit with a maximum Overcurrent Protection Device (OCPD) of 60A.

AVERTISSEMENT!

Les onduleurs triphasés 9,10,20 kW doivent être connectés à un branchement AC dédié avec un disjoncteur de 40A.

L'onduleur triphasés 14.4, 33.3 kW doivent être connectés à un branchement AC dédié avec un disjoncteur de 60A.

WARNING!

SolarEdge products can expose you to chemicals including antimony trioxide, which is known to the State of California to cause cancer. For more information, go to www.P65Warnings.ca.gov.

**AVERTISSEMENT!**

Les produits SolarEdge peut vous exposer à des agents chimiques, y compris trioxyde d'antimoine, identifiés par l'État de Californie comme pouvant causer le cancer. Pour de plus amples informations, prière de consulter www.P65Warnings.ca.gov.

CAUTION!

This unit must be operated according to the technical specification datasheet provided with the unit.

**ATTENTION!**

Cette unité doit être utilisée selon les spécifications de fonctionnement, comme décrit dans la dernière fiche technique des spécifications.

CAUTION!

HEAVY OBJECT. To avoid muscle strain or back injury, use proper lifting techniques, and if required - a lifting aid.

**ATTENTION!**

Objet lourd. Pour éviter la fatigue musculaire ou des blessures au dos, utilisez des techniques de levage appropriées et, si nécessaire - un auxiliaire de levage lors du retrait.

NOTE

The inverter is NEMA type 3R rated . Unused conduit openings and glands should be sealed with appropriate seals.

**NOTE**

- Use only copper conductors rated for a minimum of 90°C/ 194°F.
- For the SE10KUS, SE20KUS, SE33.3KUS three phase inverters where opposite polarity DC conductors are routed in the same conduit, 1000V rated cables must be used.

**NOTE**

This inverter is provided with an IMI (Isolation Monitor Interrupter) for ground fault protection.

**NOTE**

The symbol  appears at grounding points on the SolarEdge equipment. This symbol is also used in this manual.



NOTE

A SolarEdge inverter may be installed in a site with a generator, however must not operate at the same time as the generator.

Operating an inverter and a generator simultaneously will void the warranty.



SolarEdge requires installing a physical or electronic interlock, which will prevent the generator and inverter from operating simultaneously. Interlock procurement, installation, maintenance and support are the responsibility of the installer. Damage to the inverter due to incorrect interlock installation or use of an interlock that is incompatible with the SolarEdge system will render the SolarEdge warranty invalid.

IMPORTANT SAFETY INFORMATION

- Building or structures with both utility service and a PV system, complying with NEC 690.12, shall have a permanent plaque or directory including the following wording: **PHOTOVOLTAIC SYSTEM EQUIPPED WITH RAPID SHUTDOWN**. The term "PHOTOVOLTAIC" may be replaced with "PV." The plaque or directory shall be reflective, with all letters capitalized and having a minimum height of 9.5mm (3/8 in.) in white on red background.
- Attention -The system status indicator shall be installed in a location in close proximity to the system actuator, where the indication of safe shutdown can be clearly seen.
- This rapid shutdown system is required to be provided with an actuating device or a status indicator which shall be installed in a location accessible to first responders, or be connected to an automatic system which initiates rapid shutdown upon the activation of a system disconnect or activation of another type of emergency system.
- Additionally, in a prominent location near the actuator device the end use installation shall be provided with a permanent marking including the following wording: **PHOTOVOLTAIC SYSTEM EQUIPPED WITH RAPID SHUTDOWN**. The term "PHOTOVOLTAIC" may be replaced with "PV". The plaque or directory shall be reflective, with all letters capitalized and having a minimum height of 9.5mm (3/8 in.) in white on red background.



Chapter 1: Introducing the SolarEdge Power Harvesting System

The SolarEdge power harvesting solution maximizes the power output from any type of solar Photovoltaic (PV) installation while reducing the average cost per watt. The following sections describe each of the system's components.

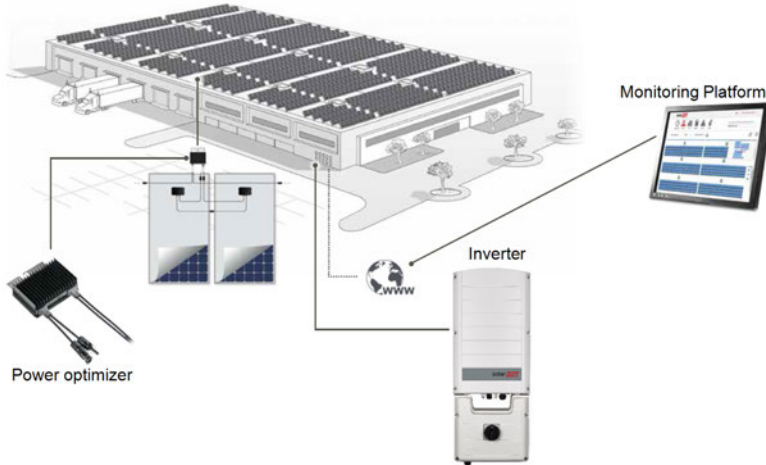

Figure 1: The SolarEdge power harvesting system components

Power Optimizer

The power optimizers are DC-DC converters connected to PV modules in order to maximize power harvesting by performing independent Maximum Power Point Tracking (MPPT) at the module level.

The power optimizers regulate the string voltage at a constant level, regardless of string length and environmental conditions.

The power optimizers include a safety voltage function that automatically reduces the output of each power optimizer to 1 Vdc in the following cases:

- During fault conditions
- The power optimizers are disconnected from the inverter
- The inverter ON/OFF switch is turned OFF
- The safety switch on the Safety Switch is turned OFF
- The inverter AC breaker is turned OFF

- The Rapid Shutdown (PVRSS) is initiated by one of the following methods:
 - Inverter AC breaker is turned OFF, or AC to the inverter is disconnected by another method (intentionally or as result of a fault)
 - Inverter ON/OFF switch is turned OFF
 - The Safety Switch is turned OFF
 - For inverters with Manual Rapid Shutdown, initiation is done by switching the Safety Switch OFF

Each power optimizer also transmits module performance data over the DC power line to the inverter.

Two types of power optimizers are available:

- Module Add-on power optimizer – connected to one or more modules
- SmartModule power optimizer is embedded into a module

Inverter with Safety Switch

The inverter efficiently converts DC power from the modules into AC power that can be fed into the main AC service of the site and from there to the grid. The inverter also receives the monitoring data from each power optimizer and transmits it to a central server (the monitoring platform; requires Internet connection).

The Safety Switch has a manually operated switch for disconnecting the DC power of a SolarEdge system.

The Safety Switch is located below the inverter and is connected to the inverter with AC and DC wires.

Monitoring Platform

The monitoring platform enables monitoring the technical and financial performance of one or more SolarEdge sites. It provides past and present information on the system performance both at the system and module levels.

Supported AC Grids

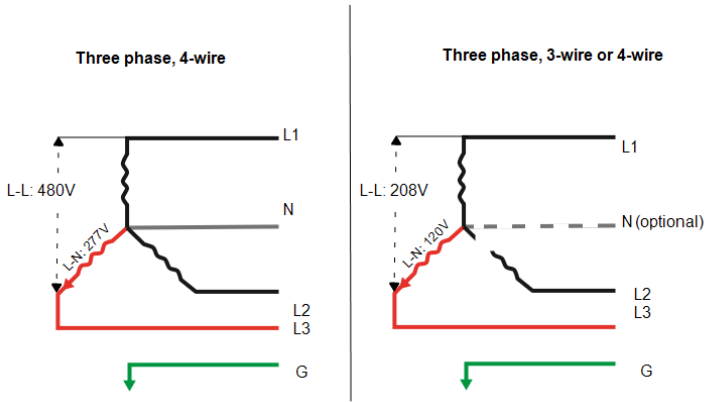

Figure 2: AC grids supported by SolarEdge three phase inverters

NOTE



Grid support depends on the inverter model. Some three phase inverters support the 208V 3-wire grid. Refer to *Setting the Inverter to Support 208V 3-wire Grid* on page 43.

Installation Procedure

The following is the procedure for installing and setting up a new SolarEdge site. Many of these also apply to modification of an existing site.

1. [Connecting Power Optimizers in Strings](#), page 25.
2. [Recording power optimizer serial numbers \(optional\)](#), page 64.
3. [Mounting the inverter](#), Page 35.
4. [Connecting the strings and the AC to the Safety Switch](#), page 41.
5. [Commissioning and activating the installation](#), page 51.
6. [Connecting the inverter to the monitoring platform](#), page 65.

Installation Equipment List

Standard tools can be used during the installation of the SolarEdge system. The following is a recommendation of the equipment needed for installation:

- Allen screwdriver for 5mm screw type for the inverter cover, Safety Switch cover, and inverter side screws
- Standard flat-head screwdrivers set

- Non-contact voltage detector
- Cordless drill (with a torque clutch) or screwdriver and bits suitable for the surface on which the inverter and optimizers will be installed and for opening the Safety Switch drill guides. Use of an impact driver is *not* allowed.
- Appropriate mounting hardware (for example: stainless bolts, nuts, and washers) for attaching:
 - the mounting brackets to the mounting surface
 - the power optimizer to the racking (not required for smart modules)
- Wire cutters
- Wire strippers
- Voltmeter

For installing the communication options, you may also need the following:

- For Ethernet:
 - CAT5/6 twisted pair Ethernet cable with RJ45 connector.
 - If using a CAT5/6 cable spool: RJ45 plug and RJ45 crimper
- For RS485:
 - Four- or six-wire shielded twisted pair cable.
 - Watchmaker precision screwdriver set

Inverter Transport and Storage

Transport the inverter in its original packaging, facing up and without exposing it to unnecessary shocks. If the original package is no longer available, use a similar box that can withstand the weight of the inverter (refer to the inverter weight in the specification datasheet provided with the unit), has a handle system and can be closed fully.

Store the inverter in a dry place where ambient temperatures are -13°F to 140°F / -25°C to +60°C.

Chapter 2: Installing the Power Optimizers

Safety

The following notes and warnings apply when installing the power optimizers. Some of the following may not be applicable to smart modules:

WARNING!



The metallic enclosure of the power optimizer must be grounded in accordance with the product's listing and local and national codes.

AVERTISSEMENT!

L'enceinte métallique de l'optimiseur de puissance doit être mise à la terre en accord avec les réglementations locales et nationales.

WARNING!



When modifying an existing installation, turn OFF the inverter ON/OFF switch, the Safety Switch and the AC circuit breaker on the main AC distribution panel.

AVERTISSEMENT!

Avant de faire ces étapes, éteignez l'onduleur monophasé en mettant sur OFF l'interrupteur ON/OFF situé au bas de l'onduleur.

CAUTION!



Power optimizers are IP68/NEMA6P rated. Choose a mounting location where optimizers will not be submerged in water.

ATTENTION!

Les optimiseurs de puissances sont compatibles à la norme IP68/NEMA6P. Choisissez le lieu de montage tel que l'optimiseur ne puisse pas être submergé par l'eau.

CAUTION!



This unit must be operated according to the operating specifications provided with the unit.

ATTENTION!

Cette unité doit être opérée suivant les instructions trouvées dans le manuel fourni avec le produit.

CAUTION!



Cutting the power optimizer input or output cable connector is prohibited and will void the warranty.

ATTENTION!

Sectionner les câbles d'entrées ou de sortie de l'optimiseur est interdit et annule sa garantie.

**CAUTION!**

All PV modules must be connected to a power optimizer.

ATTENTION!

Tous les modules doivent être connectés à un optimiseur de puissance.

CAUTION!

If you intend to mount the optimizers directly to the module or module frame, first consult the module manufacturer for guidance regarding the mounting location and the impact, if any, on module warranty. Drilling holes in the module frame should be done according to the module manufacturer instructions.

ATTENTION!

Pour installation à même le module ou la monture du module, consultez d'abord le fabricant du module sur la position et son impact sur la garantie du module. Le perçage de trous dans le cadre du module devra se faire suivant les instructions du fabricant.

CAUTION!

Installing a SolarEdge system without ensuring compatibility of the module connectors with the optimizer connectors may be unsafe and could cause functionality problems such as ground faults, resulting in inverter shut down. To ensure mechanical compatibility of the power optimizers' connectors with the PV modules' connectors to which they are connected:

- Use identical connectors from the same manufacturer and of the same type on both the power optimizers and on the modules; or
- Verify that the connectors are compatible in the following way:
 - The module connector manufacturer should explicitly verify compatibility with the SolarEdge optimizer connector; and
 - A third-party test report by one of the listed external labs (TUV, VDE, Bureau Veritas UL, CSA, InterTek) should be obtained, verifying the compatibility of the connectors.



For more information, refer to

<https://www.solaredge.com/sites/default/files/optimizer-input-connector-compatibility.pdf>



ATTENTION!

Les connecteurs du module doivent être mécaniquement compatibles avec les optimiseurs de puissance. Sinon, le système SolarEdge installé peut être dangereux ou causer des problèmes fonctionnels, tels que les défauts de terre, qui peuvent provoquer un arrêt de l'onduleur. Afin d'assurer la compatibilité mécanique entre les optimiseurs de puissance SolarEdge et les modules auxquels ils sont connectés:

- Utiliser des connecteurs identiques du même fabricant et du même type aussi bien pour les optimiseurs de puissance que pour les modules.
- Vérifiez que les connecteurs sont compatibles de la manière suivante:
 - Le fabricant du connecteur doit explicitement vérifier la compatibilité avec le connecteur SolarEdge.
 - Un rapport de test de tierce partie doit être effectué par l'un des laboratoires externes indiqués ci-dessous:(TUV, VDE, Bureau Veritas UL, CSA,Intertek), qui vérifiera la compatibilité des connecteurs.



Pour plus d'informations, consultez

<https://www.solaredge.com/sites/default/files/optimizer-input-connector-compatibility.pdf>

**IMPORTANT SAFETY FEATURE**

Modules with SolarEdge power optimizers are safe. They carry only a low safety voltage before the inverter is turned ON. As long as the power optimizers are not connected to the inverter or the inverter is turned OFF, each power optimizer will output a safe voltage of 1V.

Package Contents

- Power optimizers
- Stainless steel grounding lock washers

Installation Guidelines

- The minimum and maximum string length guidelines are stated in the power optimizer datasheets. Refer to the Designer for string length verification. The Designer is available on the SolarEdge website at <https://www.solaredge.com/us/products/installer-tools/designer#/>.

- Frame-mounted power optimizers are mounted directly on the module frame, regardless of racking system (rail-less or with rails). For installation of frame-mounted power optimizers, refer to http://www.solaredge.com/sites/default/files/installing_frame_mounted_power_optimizers.pdf. 
- The steps in this chapter refer to module add-on power optimizers. For smart modules, start from *Step 3: Connecting Power Optimizers in Strings* on page 25. Also refer to the documentation supplied with the smart modules.
- The power optimizer can be placed in any orientation.
- If connecting more modules than optimizer inputs in parallel, use a branch cable. Some commercial power optimizer models have a dual input.
- Position the power optimizer close enough to its module so that their cables can be connected.
- Make sure to use power optimizers that have the required output conductor length:
 - *Do not* use extension cables between a module and a power optimizer, between two modules connected to the same optimizer, or between two optimizers other than in the cases specified below.
 - You can use extension cables between power optimizers only from row to row, around obstacles within a row, and from the end of the string to the inverter, as long as the maximum distance is not exceeded.

NOTE

- The total conductor length of the string (excluding power optimizers' conductors; including home runs and necessary extensions between optimizers) should not exceed the following:



Inverter model	Total conductor length (from DC+ to DC- of the inverter)
SE9KUS, SE10KUS, SE20KUS	1000 ft. /300 m
SE14.4KUS, SE33.3KUS	2300 ft./ 700 m

- Use at least 11 AWG/ 4 mm² DC cables.
- Completely shaded modules may cause their power optimizers to temporarily shut down. This will not affect the performance of the other power optimizers in the string, as long as the minimum number of unshaded power optimizers connected in a string of modules is met. If under typical conditions fewer than the minimum optimizers are connected to unshaded modules, add more optimizers to the string.
 - Equipment grounding tightening torques: 4-6 AWG: 45 lb-in, 8 AWG: 40 lb-in, 10-14 AWG: 35 lb-in.
 - To allow for heat dissipation, maintain a 2.5 cm / 1" clearance distance between the power optimizer and other surfaces, on all sides except the mounting bracket side.

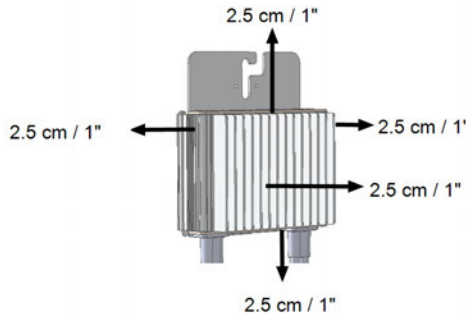

Figure 3: Power optimizer clearance

- When installing modules in a confined space, for example, if installing Building-integrated photovoltaic (BIPV) modules, ventilation measures may be needed to ensure the power optimizers are not be exposed to temperatures outside their specifications.

NOTE

The images contained herein are for illustrative purposes only and may vary depending on product models.

Step 1: Mounting and Grounding the Power Optimizers

For each of the power optimizers⁽¹⁾:

1. Determine the power optimizer mounting location and use the power optimizer mounting brackets to attach the power optimizer to the support structure (See *Figure 4*). It is recommended to mount the power optimizer in a location protected from direct sunlight. For frame-mounted power optimizers follow the instructions supplied with the optimizers, or refer to https://www.solaredge.com/sites/default/files/installing_frame_mounted_power_optimizers.pdf.
2. If required, mark the mounting hole locations and drill the hole.



CAUTION!



Drilling vibrations may damage the power optimizer and will void the warranty. Use a torque wrench or an electric drill with adjustable clutch that meets the mounting torque requirements. *Do not* use impact drivers for mounting the power optimizer.

Do not drill through the power optimizer or through the mounting holes.

ATTENTION!

Les vibrations résultant du perçage peuvent endommager l'optimiseur de puissance et annulera la garantie. Utilisez une clé dynamométrique ou une perceuse électrique avec embrayage adaptable compatible avec les moments indiqués. Ne pas utiliser des tournevis à percussion pour fixer l'optimiseur. Ne pas percer à travers l'optimiseur de puissance ou ses trous de fixation.

3. Attach each power optimizer to the rack using M6 (1/4") stainless steel bolts, nuts and washers or other appropriate mounting hardware. Apply torque of 9-10 N*m / 6.5-7 lb*ft.

For 3NA series power optimizers, SolarEdge recommends mounting the power optimizer on a rail with the smooth side facing out, so that the power optimizer body will prevent its rotation.

⁽¹⁾Not applicable to smart modules.

4. Use the following methods⁽¹⁾ to ground the power optimizer:

WARNING!



The metallic enclosure of the power optimizer must be grounded in accordance with the requirements of the local and national codes.

AVERTISSEMENT!

L'enceinte métallique de l'optimiseur de puissance doit être mise à la terre en accord avec les réglementations locales et nationales.

- **For mounting on a grounded metal rail:** Use the provided 5/16" stainless steel grounding star washer between the railing and the flat side of the mounting bracket. The grounding washer should break through the anodize coating of the railing to ensure low resistive connection. Apply torque of 9.5 N*m / 7 lb*ft. See *Figure 4*.

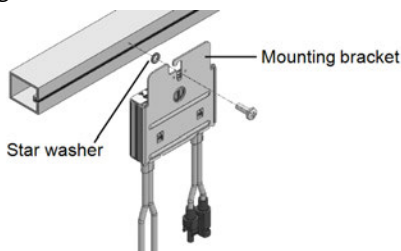

Figure 4: Power optimizer installation and grounding using a star washer

- **For mounting on rails with sliding nut fasteners:** If the star washer cannot be used, use the SolarEdge grounding plate (purchased separately) between the railing and the flat side of the mounting bracket. Use mounting specific hardware as needed. Apply torque of 9.5 N*m / 7 lb*ft. See *Figure 5*.

⁽¹⁾These methods have been evaluated by a nationally recognized testing laboratory as part of the optimizer evaluation. The SolarEdge-supplied grounding lug kit has been evaluated only for use with SolarEdge power optimizers. It is not intended or listed to be used as a general purpose grounding lug with other electrical equipment.

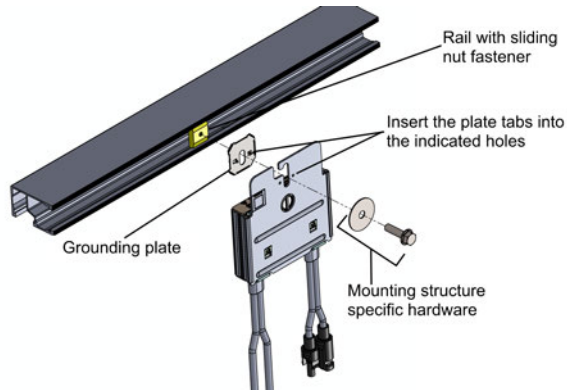

Figure 5: Power optimizer installation and grounding using a grounding plate

- **For mounting on un-grounded structures** (such as a wooden structure): If the star washer or the plate cannot be used, use the SolarEdge grounding lug (purchased separately) with an equipment-grounding conductor according to the supplied instructions. The grounding terminal accepts a wire size of 6-14 AWG, and must be sized for equipment grounding per NEC 250.122 requirements. Tighten the screws connecting the power optimizer to the frame and the grounding terminal screw. Apply torque of 9.5 N*m / 7 lb*ft. See *Figure 6*.

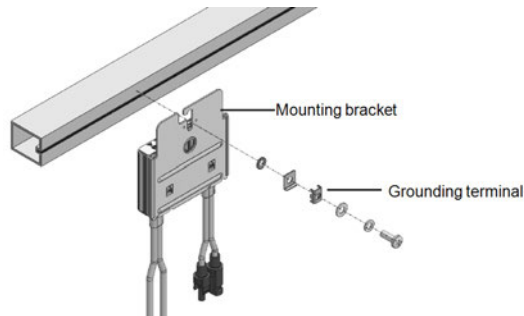

Figure 6: Power optimizer grounding terminal

5. Verify that each power optimizer is securely attached to the module support structure.
6. Record power optimizer serial numbers and locations, as described in *Reporting and Monitoring Installation Data* on page 63.

Step 2: Connecting a PV Module to a Power Optimizer



NOTE

Images are for illustration purposes only. Refer to the label on the product to identify the plus and minus input and output connectors.

For each of the power optimizers:

- Connect the Plus (+) output connector of the module to the Plus (+) input connector of the power optimizer.
- Connect the Minus (-) output connector of the module to the Minus (-) input connector of the power optimizer.

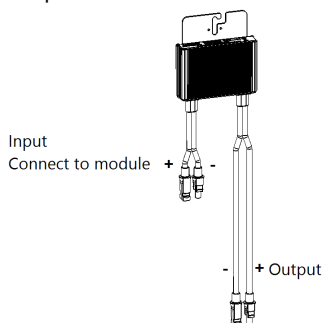

Figure 7: Power optimizer connectors

Step 3: Connecting Power Optimizers in Strings

You can construct parallel strings of unequal length, that is, the number of power optimizers in each string does not have to be the same. The minimum and maximum string lengths are specified in the power optimizer datasheets. Refer to the [Designer](#) for string length verification.



IMPORTANT SAFETY FEATURE



For a compliant PV Rapid Shutdown System (PVRSS) installation, use no more than 30 optimizers per string.

1. Connect the Minus (-) output connector of the string's first power optimizer to the Plus (+) output connector of the string's second power optimizer.
2. Connect the rest of the power optimizers in the string in the same manner.

WARNING!



If using a dual-input power optimizer and some inputs are not used, seal the unused input connectors with the supplied pair of seals.

AVERTISSEMENT!

Si un optimiseur à double entrées est utilisé et que certaines entrées ne sont pas connectées, fermez ces entrées avec la paire de couvercles fournie.

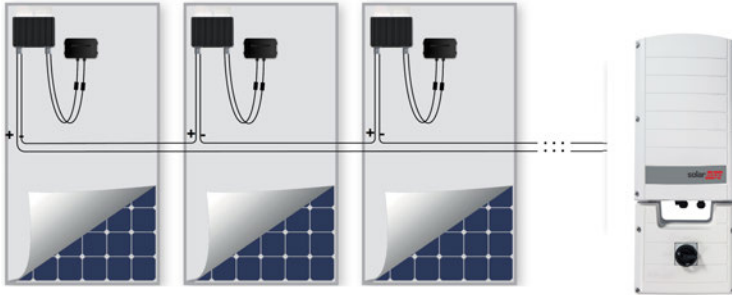

Figure 8: Power optimizers connected in series

3. If you intend to monitor the installation, using the monitoring platform, record the physical location of each power optimizer, as described in *Creating Logical and Physical Layout using Installation Information* on page 64.

Step 4: Verifying Proper Power Optimizer Connection

When a module is connected to a power optimizer, the power optimizer outputs a safe voltage of 1V ($\pm 0.1V$). Therefore, the total string voltage should equal 1V times the number of power optimizers connected in series in the string. For example, if 10 power optimizers are connected in a string, then 10V should be produced.

Make sure the PV modules are exposed to sunlight during this process. The power optimizer will only turn ON if the PV module provides at least 2W.

In SolarEdge systems, due to the introduction of power optimizers between the PV modules and the inverter, the short circuit current I_{SC} and the open circuit voltage V_{OC} hold different meanings from those in traditional systems.

For more information about the SolarEdge system's string voltage and current, refer to the *V_{OC} and I_{SC} in SolarEdge Systems Technical Note*, available on the SolarEdge website at:

https://www.solaredge.com/sites/default/files/isc_and_voc_in_solaredge_sysems_technical_note.pdf.



→ To verify proper power optimizer connection:

Measure the voltage of each string individually before connecting it to the other strings or to the inverter. Verify correct polarity by measuring the string polarity with a voltmeter. Use a voltmeter with at least 0.1V measurement accuracy.

**NOTE**

Since the inverter is not yet operating, you may measure the string voltage and verify correct polarity on the DC wires inside the Safety Switch.

For troubleshooting power optimizer operation problems, refer to *Power Optimizer Troubleshooting* on page 82.

Chapter 3: Installing the Inverter

Install the inverter either before or after the modules and power optimizers have been installed.

NOTE



- Use only copper conductors rated for a minimum of 90°C/ 194°F.
- For the SE10KUS, SE20KUS, SE33.3KUS three phase inverters where opposite polarity DC conductors are routed in the same conduit, 1000V rated cables must be used.

Inverter Package Contents

- One inverter with Safety Switch
- One mounting bracket
- Two Allen screws for fastening the inverter to the mounting bracket
- Quick Installation guide
- Optional (for wireless communication to monitoring platform) - RF antenna and mounting bracket
- AC ferrite bead kit

Identifying the Inverter

Refer to the sticker on the inverter that specifies its **Serial Number** and its **Electrical Ratings**. Provide the serial number when contacting SolarEdge support. The serial number is also required when opening a new site in the monitoring platform.

Inverter Interfaces

The following figure shows the inverter connectors and components, located at the bottom of the inverter.

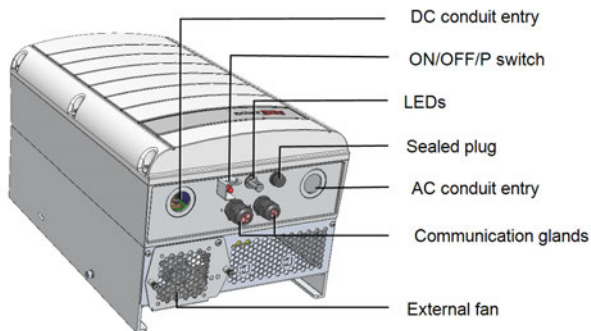

Figure 9: Inverter Interfaces

- **AC output:** AC output gland, AC cable external gauge, M32 (15-21mm diameter) for connection to the grid
- **AC and DC conduit entries:** Connection points of the Safety Switch.
- **Two communication glands:** for connection of inverter communication options. Each gland has three openings. Refer to *Setting Up Communication* on page 66 for more information.
- **Drain valve:** Drains any moisture that may be accumulated in the unit.
- **ON/OFF/P Switch:**



P = Program/Pair
 1 = ON
 0 = OFF

Figure 10: ON/OFF/P switch

- **ON (1)** - Turning this switch ON (after optimizer pairing) starts the operation of the power optimizers, enables power production and allows the inverter to begin exporting power to the utility grid.
- **OFF (0)** - Turning this switch OFF reduces the power optimizer voltage to a low safety voltage and inhibits exportation of power. When this switch is OFF, the control circuitry remains powered up.
- **P** - Moving and releasing the switch allows viewing system information via the LEDs and on the SolarEdge SetApp mobile application screen, and performing the following functions:

P Position duration	Function	Comments
Switch moved to P for less than 5 seconds , then released.	<ul style="list-style-type: none"> Displays (via LEDs) production information for 5 seconds, or error type indications (if exist) for 5 seconds. Activates the Wi-Fi access point for connecting to the SetApp 	<p>While the switch is in P, all LEDs are ON.</p> <p>When the switch is released all LEDs turn OFF for 0.5 sec and then display the production or error indication.</p>
Switch moved to P for more than 5 seconds , then released.	Starts pairing	Pairing is indicated by all 3 LEDs blinking simultaneously.

- **LEDs:** three LEDs indicate, by color and state (on/ off/ blinking⁽¹⁾/ flickering⁽²⁾/alternating⁽³⁾), different system information, such as errors or performance indications. For more information, refer to <https://www.solaredge.com/leds>.

The main LED indications are:

- Blue ON - the inverter is communicating with the monitoring platform
- Green ON - the system is producing
- Green blinking - AC is connected but the system is not producing
- Red ON - system error



(1)Blinking = Turns ON and OFF for the same duration

(2)Flickering = Turns ON for 100 mS and turns OFF for 5 seconds

(3)Alternating = alternate LED flashes

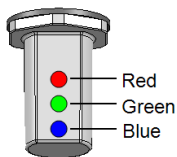

Figure 11: LEDs

The following table describes system performance information by LED color and ON/OFF/P switch position.

Indication	ON/ OFF/ P switch position	LED color			Comment
		Red	Green	Blue	
Power optimizers not paired	ON (1)	OFF	Blinking	<ul style="list-style-type: none"> • S_OK: ON • No S_OK: OFF 	S_OK: ON communication with the monitoring platform is established.
Pairing		Blinking	Blinking	Blinking	
Wake-up/ Grid Monitoring		OFF	Blinking	Blinking	
System Producing		OFF	ON	<ul style="list-style-type: none"> • S_OK: ON • No S_OK: OFF 	
Night mode (no production)		OFF	Flickering	<ul style="list-style-type: none"> • S_OK: ON • No S_OK: OFF 	
Inverter is OFF (Safe DC)	OFF (0)	OFF	Blinking	<ul style="list-style-type: none"> • S_OK: ON • No S_OK: OFF 	
Inverter is OFF (DC not safe)		Blinking	Blinking	<ul style="list-style-type: none"> • S_OK: ON • No S_OK: OFF 	

Indication	ON/ OFF/ P switch position	LED color			Comment
		Red	Green	Blue	
Inverter configuration or reboot	ON / P	ON	ON	ON	
Inverter firmware upgrade	ON / P	Alternating	Alternating	Alternating	The upgrade process can take up to 5 minutes
Error	Any	ON	ON/ OFF/ Blinking/ Flickering	ON/ OFF / Blinking	Refer to <i>Errors and Troubleshooting</i> on page 79

The following table describes production percentage of AC information by LED color and ON/OFF/P switch position.

Indication	ON/ OFF/ P switch position	LED color			Comment
		Red	Green	Blue	
Percentage of AC Production: 0 %	ON (1)	OFF	OFF	OFF	This indicates power production as percentage of rated peak AC output power
Percentage of AC Production: 0 - 33 %		OFF	ON	OFF	
Percentage of AC Production: 33 - 66 %		OFF	OFF	ON	
Percentage of AC Production: 66 - 100 %		OFF	ON	ON	

■ **DC Safety Unit**, including:

- **ON/OFF switch**: connects and disconnects the DC power of the system
- **AC conduit entries** for connection to the grid
- **DC AC conduit entries** for connection of the PV installation



Figure 12: DC Safety Unit

NOTE

When the Safety Switch is OFF (for example during maintenance) it may be locked to prevent a safety hazard:



1. Move the switch to the Lock position.
2. Insert the lock through the knob opening and lock.



Opening Conduit Drill Guides

This section describes how to open drill guides .

CAUTION!

SolarEdge does not permit opening or puncturing the Safety Switch in any location other than the pre-defined drill guide locations, or otherwise altering the construction of the enclosure, as this may compromise safety and will void the warranty. This includes, but is not limited to, the use of fasteners like rivets, screws, nails, inserts, or pins.



For jurisdictions requiring field applied markings on the Safety Switch enclosure, such as labels or placards that display PV system information, adhesive labels or placards that comply with ANSI Z535 and are compatible with the enclosure material may be used.

ATTENTION!

SolarEdge n'autorise pas l'ouverture or la perforation du commutateur de sécurité a tout endroit autre que les emplacements de perforation guidés prédéfinis, ou la modification de l'enceinte électrique, car cela compromettrait la sécurité et annulerait la garantie. Ceci inclus, sans être limité à, l'utilisation de fixations comme des rivets, vis, clous, inserts ou des broches.

Pour les juridictions ou un marquage de sécurité est requis sur le couvercle du coupeur DC, tels que des labels ou étiquettes qui figurent des information du système PV, des labels ou étiquettes adhésifs compatibles avec ANSI Z535 peuvent être utilisés qui sont compatibles avec le matériau du couvercle.

This step may be performed before or after mounting the inverter.

→ To open conduit drill guides:

1. Move the Safety Switch and the inverter ON/OFF switch to OFF.

- Loosen the screws on the front cover of the Safety Switch , as shown below:

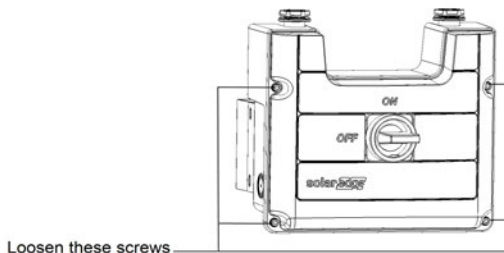

Figure 13: Opening the Safety Switch cover

- Remove the Safety Switch cover.
- Open the required AC and DC conduit drill guides according to the conduits used in the installation: The drill guides are located at the bottom, back and sides of the enclosure, each with two sizes: 3/4" and 1". Open the required pair, taking care not to interfere with any of the internal components. It is recommended to use a Unibit drill.

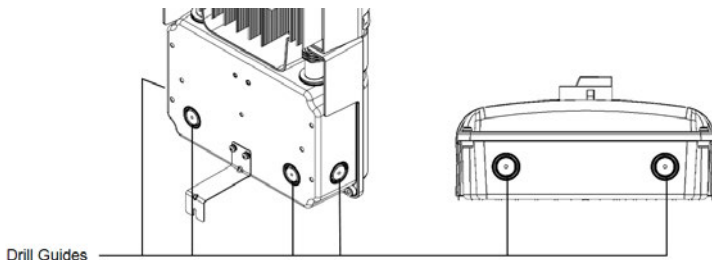

Figure 14: Safety Switch drill guides



NOTE

Unused conduit openings and glands should be sealed with appropriate seals.

Mounting the Inverter

The inverter is typically mounted vertically, and the instructions in this section are applicable for vertical installation. Some three phase inverter models can be installed horizontally (above 10° tilt) as well as vertically, and at any tilt over 10° up to 90°. For information and instructions for horizontal mounting refer to

http://www.solaredge.com/sites/default/files/application_note_horizontal_mounting_of_three_phase_inverters.pdf.



The inverter is supplied with a mounting bracket.

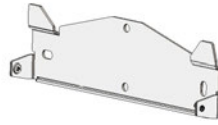

Figure 15: Mounting bracket

NOTE



Make sure the mounting surface or structure can support the weight of the inverter and bracket, and make sure that it spans the width of the bracket.

CAUTION!

HEAVY OBJECT. To avoid muscle strain or back injury, use proper lifting techniques, and if required - a lifting aid.



ATTENTION!

Objet lourd. Pour éviter la fatigue musculaire ou des blessures au dos, utilisez des techniques de levage appropriées et, si nécessaire - un auxiliaire de levage lors du retrait.

CAUTION!



SolarEdge inverters and power optimizers can be installed at a minimum distance of 50 m/ 164 ft from the shoreline of an ocean or other saline environment, as long as there are no direct salt water splashes on the inverter or power optimizer.

ATTENTION!

Les onduleurs SolarEdge peuvent être installés à une distance minimum de 50m de la ligne d'eau de l'océan ou autre environnement salin, tant qu'il n'y a pas d'éclaboussements d'eau salée directs sur l'onduleur.

1. Determine the inverter mounting location, on a wall, stud framing or pole. It is recommended to mount the inverter in a location protected from direct sunlight.
2. To allow proper heat dissipation, maintain the following minimum clearance areas between the inverter and other objects:
 - If installing a single inverter:
 - 8" (20 cm) from the top of the inverter.
 - At least 4" (10 cm) from the bottom of the Safety Switch; if conduit entry to the Safety Switch will be from the bottom, leave sufficient clearance for the conduits as well.
 - 4" (10 cm) from the right and left of the inverter. For easy access to the fans, a larger clearance is recommended.
 - If installing multiple inverters:

- When installing inverters one above the other, leave at least 8" (20 cm) between the top of an inverter and the bottom of the Safety Switch.
- When installing inverters side by side, follow these clearance specifications:

Location	Indoor Installation	Outdoor Installation
Locations where the annual average high temperature ⁽¹⁾ is below 25°C / 77°F	20 cm / 8" between inverters	5 cm / 2" between inverters (if inverters are also installed one above the other, maintain the indoor installation clearance)
Locations where the annual average high temperature ¹ is above 25°C / 77°F	40 cm / 16" between inverters	

(1)Annual average high temperature – the average of the 12 monthly average highs, for example:

Average High Temperature												Years on Record: 20	
C	ANNUAL	JAN	FEB	MAR	APR	MAY	JUN	JUL	AUG	SEP	OCT	NOV	DEC
	21.5	11.8	12.6	15.4	21.5	25.3	27.6	29	29.4	28.2	24.7	18.8	14

Refer to <http://www.weatherbase.com/> to find the value in your location.

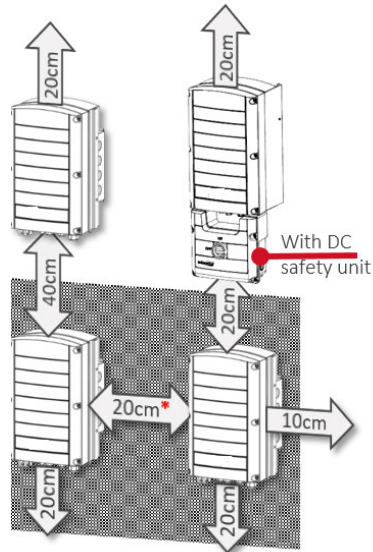
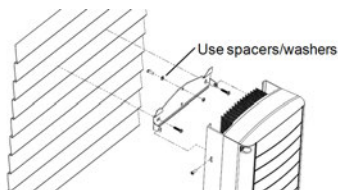

Figure 16: Clearance

3. Position the mounting bracket against the wall/pole and mark the drilling hole locations (refer to *Mechanical Specifications* on page 84 for inverter and mounting bracket dimensions):
 - Ensure that the flat edge of the bracket is at the bottom, as in *Figure 17*.
 - Use at least two bracket holes. Additional holes can be used to fix the bracket. Determine which and how many holes to use according to mounting surface type and material.
4. Drill the holes and mount the bracket. Verify that the bracket is firmly attached to the mounting surface.

NOTE

When mounting an inverter on an uneven surface, you may use spacers/washers behind the top mounting hole of the bracket. Depending on the angle, use the appropriate size and number of spacers so that the bracket is perpendicular to the ground. Recommended: a stainless steel 3/4" long screw, with a 1/4" socket button head, two jam nuts and three washers.



- Hang the inverter on the bracket (see *Figure 17*): Lift the inverter from the sides, or hold it at the top and bottom of the inverter to lift the unit into place. Do not lift holding the Safety SwitchDC Safety Unit as it may be damaged.
- Align the two indentations in the inverter enclosure with the two triangular mounting tabs of the bracket, and lower the inverter until it rests on the bracket evenly.

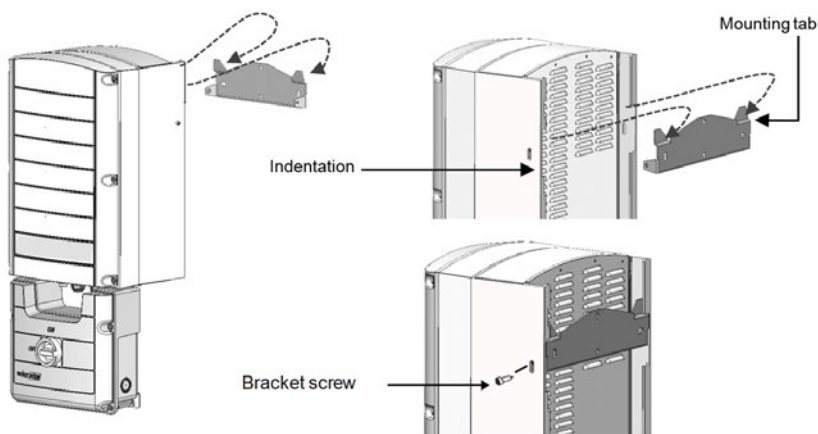

Figure 17: Hanging the inverter on the bracket

- Secure the Safety Switch bracket to the wall:
- For inverters with Safety Switch - secure the Safety Switch bracket to the wall:
 - Mark the location of the bracket screw for the Safety Switch and drill the hole.

- Fasten the bracket using a standard bolt.
- Verify that the bracket is firmly attached to the mounting surface.

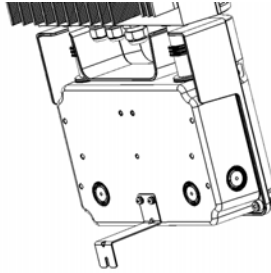

Figure 18: Safety Switch bracket

9. Insert the two supplied screws through the outer heat sink fin on both sides of the inverter and into the bracket (see *Figure 17*). Tighten the screws with a torque of 4.0 N*m / 2.9 lb.*ft.

Chapter 4: Connecting the AC and the Strings to the Safety Switch

The Safety Switch disconnects all ungrounded DC conductors in compliance with the National Electric Code (NEC; Specifically NEC690.35, which addresses ungrounded PV arrays). The Safety Switch is rated to the maximum operating conditions of the inverter. Inverters of different models are equipped with different sizes/ types of terminal blocks. The following figures illustrate several of the available Safety Switches.

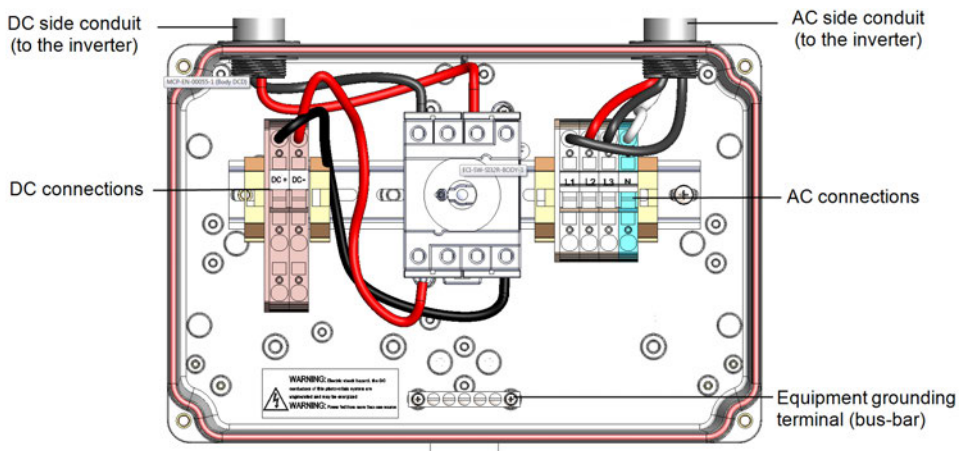

Figure 19: Inside the Safety Switch for three phase inverters (9kW, 10kW, 20kW)

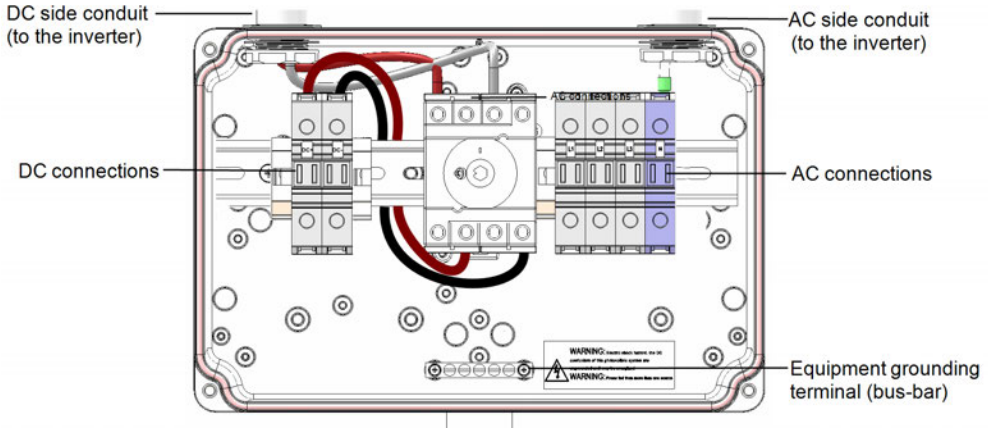

Figure 20: Inside the Safety Switch for three phase inverters
(14.4kW & 33.3kW)

Grid Connection Guidelines

- Equipment grounding tightening torques: 4-6 AWG: 45 lb-in, 8 AWG: 40 lb-in, 10-14 AWG: 35 lb-in.
- The conduits, hubs and fittings must be suited for field wiring systems.
- The hubs and other fittings must comply with UL514B.
- Use only copper conductors rated for a minimum of 90°C.
- For the SE10KUS, SE20KUS, SE33.3KUS three phase inverters where opposite polarity DC conductors are routed in the same conduit, 1000V rated cables must be used.
- Use the conduit and wiring appropriate for the installation location per the NEC. Outdoor installations must use components that are rated NEMA 3R or higher.

NOTE

For more wiring information refer to the *SolarEdge Recommended AC Wiring Application Note*, available on the SolarEdge website at <https://www.solaredge.com/sites/default/files/application-note-recommended-wiring.pdf>



Setting the Inverter to Support 208V 3-wire Grid

SolarEdge inverters that support the 208V 3-wire grid are equipped with two fuse holders and a fuse in each unit. The position of the fuse configures the AC grid connection: 4-wire or 3-wire grid connection. By default, the fuse is located in the 4-wire fuse holder of the inverter, and in the 3-wire fuse holder there is a plastic dummy fuse.

To set the inverter for 3-wire grid connection, you must move the fuse from the 4-wire fuse holder, marked as Y GRID, to the 3-wire fuse holder, marked as Δ GRID (see *Figure 21*).

→ To set the inverter for 208V 3-wire grid connection:



NOTE

Perform this procedure for all inverter units.



NOTE

Perform this procedure before connecting the inverter to the AC grid.

1. Remove the inverter cover: Open the inverter cover's six Allen screws and carefully pull the cover horizontally before lowering it.
2. Identify the fuse locations and the markings as described in *Figure 21*.

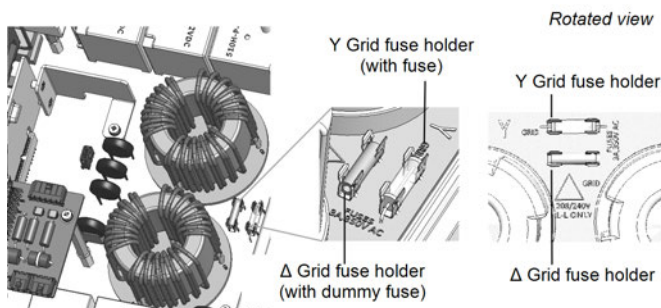

Figure 21: Fuse locations and markings

3. Remove the dummy fuse from the 3-wire grid fuse holder and set it aside.
4. Move the fuse from the 4-wire grid fuse holder to the 3-wire grid fuse holder.
5. Place the dummy fuse in the 4-wire grid fuse holder.
6. During system setup, set the country to the appropriate 3-wire grid option. Using the non-3-wire setting may result in incorrect system operation.

CAUTION!

If the fuse was moved to support one of the grid types, do not connect the inverter to the other grid type without switching the fuse back to the correct holder. Connecting the inverter to grids when the fuse is incorrectly located may damage the inverter and void the warranty.

ATTENTION!

Si le fusible a été déplacé pour supporter l'un des types de réseau, ne branchez pas l'onduleur sur l'autre type de réseau avant de remettre le fusible dans son bon support. Brancher l'onduleur au réseau quand le fusible est mal placé, peut endommager l'onduleur et annuler la garantie.

Connecting the AC Grid to the Safety Switch

CAUTION!

Do not remove or disconnect the meter during inverter installation.

**ATTENTION!**

Ne pas enlever ou débrancher le compteur pendant l'installation de l'onduleur.

CAUTION!

When moving the pivoting plate, make sure that the wires are not strained to avoid loosening the connections. When flipping the plate up to its original position, check for loose wires or connectors, and when closing the inverter, recheck for proper functionality as described in this procedure.

**ATTENTION!**

Si vous faites pivoter le couvercle du compteur, faites attention de ne pas tendre les câbles au point d'affaiblir les connexions. Quand vous remettez le couvercle à sa position originelle, vérifiez que les câbles ou les connecteurs ne sont pas détachés, et quand vous refermerez l'onduleur, revérifiez son fonctionnement tel qu'il est décrit dans cette procédure.

NOTE

- Use only copper conductors rated for a minimum of 90°C/ 194°F.
- For the SE10KUS, SE20KUS, SE33.3KUS three phase inverters where opposite polarity DC conductors are routed in the same conduit, 1000V rated cables must be used.

→ To connect AC to ground:

1. Insert the grounding cable through the AC drill guide.
2. Connect the cable to the equipment grounding bus-bar. Tighten using a torque of 4.0 N*M / 35 lb-in.

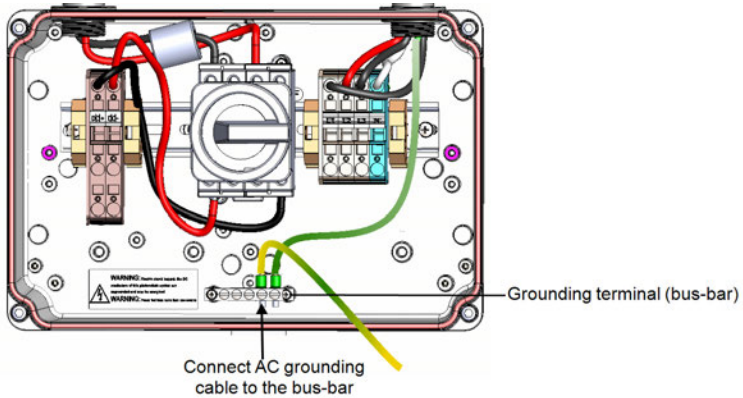

Figure 22: AC grounding in the Safety Switch



NOTE

The Safety Switches are equipped with different types of terminal blocks. The above figure is one example of the available Safety Switches.

→ To connect the AC grid to the Safety Switch – 14.4 & 33.3kW inverters:

1. Remove the spring-clamp terminal instructions from inside the switch.
2. Strip 1 $\frac{3}{8}$ " (35mm) of the AC wire insulation.
3. Insert the AC conduit into the AC-side drill guide that was opened.

NOTE



Connect the equipment grounding before connecting the AC wires to the AC terminal block.

Veillez à relier le conducteur de PE (la terre) avant de connecter les fils CA au bornier CA.

4. Connect the wires to the appropriate terminal blocks according to the labels on the terminal blocks (N, L1, L2, L3).
5. Use a 13/64" (5mm) straight flat-blade screwdriver to connect the wires to the terminals:
 1. Insert the screwdriver into the front opening and rotate it counterclockwise to activate the clamp mechanism. The side latch holds the clamp in the open position.
 2. Insert the wire into the side opening as deep as possible.
 3. Slightly rotate the screwdriver counter-clockwise to release the latch.
 4. Remove the screwdriver – the wire is safely clamped.

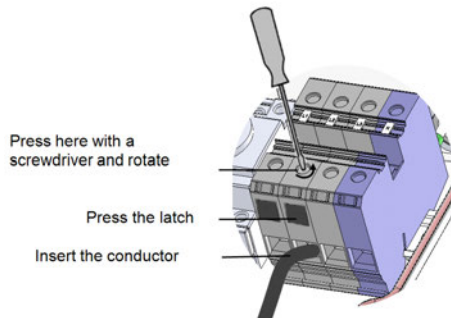

Figure 23: AC Spring-clamp terminal example - 33.3KW inverter

6. Verify that there are no unconnected wires.

→ To connect the AC grid to the Safety Switch – 9kW, 10kW, 20kW:

1. Strip 05/16" (8mm) of the AC wire insulation.
2. Insert the AC conduit into the AC-side drill guide that was opened.

NOTE



Connect the equipment grounding before connecting the AC wires to the AC.

Veillez à relier le conducteur de PE (la terre) avant de connecter les fils CA au bornier CA.

3. Connect the wires as follows:
 1. Use a standard flat-blade screwdriver to connect the wires to the spring-clamp terminals (See *Figure 24*).
 2. The screwdriver blade should fit freely in the terminal opening. Too large a blade can crack the plastic housing.
 3. Insert the screwdriver, press the release mechanism and open the clamp.
 4. Insert the wire into the round opening and remove the screwdriver – the wire is automatically clamped.

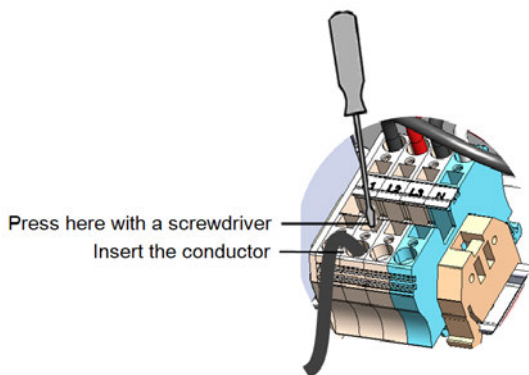

Figure 24: AC Spring-clamp terminal – 9kW, 10kW, 20kW inverter

Connecting the Strings to the Safety Switch

You can connect systems with multiple DC strings in parallel to the DC input terminals of the switch. Inverters have one, two or three pairs of DC input terminals, depending on the inverter power rating. If more strings are required, they can be connected in parallel using an external combiner box before connecting to the switch. When connecting multiple strings, it is recommended to run separate circuits to the Safety Switch or to position the combiner box near the switch. This simplifies commissioning by allowing testing and servicing near the inverter.

→ To connect the strings to the safety switch:

1. Strip 5/16" (8 mm) of the DC wire insulation.
2. Insert the DC conduit into the DC-side drill guide that was opened.
3. Equipment grounding: Connect the DC equipment ground conductor to the equipment grounding terminal block in the Safety Switch.

NOTE



Functional Electrical Earthing of DC-side negative or positive is prohibited because the inverter has no transformer. Equipment grounding of exposed conductive surfaces in the array is required per the NEC.

4. Connect the DC wires:

CAUTION!



Ensure that the Plus (+) wire(s) is connected to the (+) terminal and that the Minus (-) wire is connected to the Minus (-) terminal connector.

ATTENTION!

Veillez à ce que le câble(s) Plus (+) soit connecté au terminal (+) et que le câble (-) soit connecté au (-) terminal.

NOTE



For systems with four PV strings per unit or more, fuses may need to be installed in both the positive and negative conductors as required by NEC Article 690.9. For more information, refer to the "String Fusing Requirements in SolarEdge Systems" technical note at http://www.solaredge.com/files/pdfs/string_fusing_requirements.pdf.



NOTE



SolarEdge's fixed input voltage architecture enables the parallel strings to be of different lengths. Therefore, they do not need to have the same number of power optimizers, as long as the length of each string is within the permitted range.

- For three phase inverters 9kW, 10kW and 20kW - Connect the DC wires from the PV installation to the DC+ and DC- terminal blocks, according to the labels on the terminals:
 - Use a standard flat-blade screwdriver to connect the wires to the spring-clamp terminals. The screwdriver blade should fit freely in the terminal opening. Too large a blade can crack the plastic housing. See *Figure 25*
 - Insert the screwdriver and firmly tilt it to press the release mechanism and open the clamp.
 - Insert the wire into the front opening .
 - Remove the screwdriver – the wire is automatically clamped. Check that the wire is fully inserted and cannot be pulled out easily.

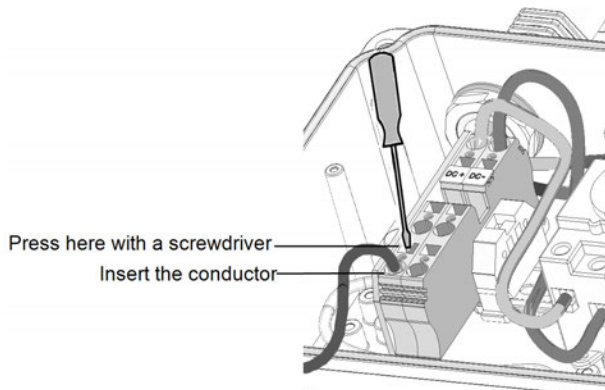

Figure 25: DC Spring-clamp terminal example - 9kW, 10kW and 20kW inverters

- For three phase inverters 14.4kW and 33.3kW – Connect the DC wires from the PV installation to the DC+ and DC- terminal blocks :
 - Insert the screwdriver into the front opening and rotate it counterclockwise to activate the clamp mechanism. The side latch holds the clamp in the open position.
 - Insert the wire into the side opening as deep as possible.
 - Slightly rotate the screwdriver counter-clockwise to release the latch.
 - Remove the screwdriver – the wire is safely clamped.

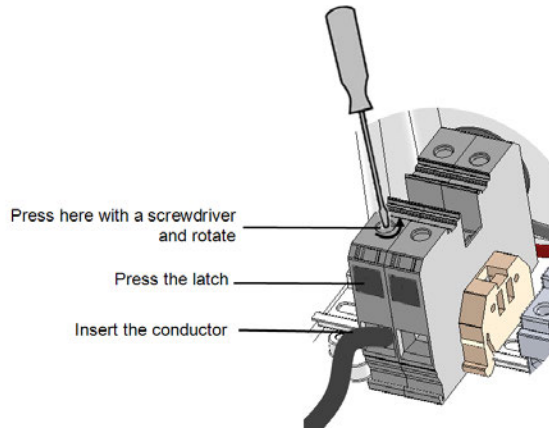

Figure 26: DC Spring-clamp terminal – 14.4kW and 33.3kW inverters

5. Close the Safety Switch cover: Attach the switch cover and secure it by tightening the four screws with a torque of 1.2 N*m / 0.9 ft.*lb.
6. Ensure proper conduit sealing; inspect the entire conduit run and use standard conduit sealants to avoid water penetration.

Chapter 5: Activating, Commissioning and Configuring the System Using the Inverter SetApp

If applicable, you can connect communication options at this stage, as described in *Setting Up Communication* on page 66.

Once all connections are made, the system should be activated and commissioned using the Inverter SetApp mobile application. You can download the app from the Apple App Store and Google Play prior to reaching the site.



Internet connection is required for the download and for the one-time registration, however not required for using the SetApp.

Step 1: Activating the Installation

During system activation, a Wi-Fi connection is created between the mobile device and the inverter and the system firmware is upgraded.

Before activation - download, register (first time only) and log-in to SetApp on your mobile device. Internet connection is required for the download and for the one-time registration. Verify that the application is updated with the latest version.

→ **To activate the inverter:**

1. Turn ON the AC circuit breaker on the main distribution panel.
2. Open SetApp and follow the instructions on the screen (scan the inverter bar-code; move the ON/OFF/P switch to P position and release within 5 sec. back to ON (1) position). SetApp creates a Wi-Fi connection, upgrades the inverter CPU firmware and activates the inverter.

3. When the activation is complete, do one of the following:
 - Select **Activate Another Inverter** to continue activating additional inverters
 - Select **Start Commissioning** for pairing and other system configuration. The Commissioning screen is displayed. Refer to the next section for more information.

Step 2: Commissioning and Configuring the Installation

This section describes how to use the SetApp menus for commissioning and configuring the inverter settings.

Menus may vary in your application depending on your system type.

→ To access the Commissioning screen:

Do one of the following:

- During first time installation: Upon Activation completion, in the SetApp, tap **Start Commissioning**. The main Commissioning menu screen is displayed.
- If the inverter has already been activated and commissioned:
 - If not already ON - turn ON AC to the inverter by turning ON the circuit breaker on the main distribution panel.
 - Open SetApp and follow the instructions on the screen (scan the inverter bar-code; move the ON/OFF/P switch to P position (for less than 5 sec) and release).
The mobile device creates a Wi-Fi connection with the inverter and displays the main Commissioning screen.

In the main menus, tap the menu red arrows (➤) to perform the system commissioning or configuration task. Tap the **Back** arrow (◀) to return to the previous menu.

The next sections provide more information about configuration options (in addition to **Country and Language** and **Pairing**, described in *Step 2: Commissioning and Configuring the Installation* on page 52).

Setting Country and Language

1. From the Commissioning screen select **Country and Language** .
2. From the **Country** drop-down list, select the required country setting.

WARNING!

The inverter must be configured to the proper setting in order to ensure that it complies with the country grid code and functions properly with the country grids.

AVERTISSEMENT!

L'onduleur doit être configuré pour le pays approprié afin d'assurer un fonctionnement convenable avec le réseau de ce pays.

3. From the **Language** drop-down list, select the language.
4. Tap **Set Language**.

Pairing

1. From the main menu, select **Pairing**.
2. Tap **Start Pairing**.
3. When **Pairing Complete** is displayed, the system startup process begins: Since the inverter is ON, the power optimizers start producing power and the inverter starts converting AC.

WARNING!

When you turn ON the inverter ON/OFF/P switch, the DC cables carry a high voltage and the power optimizers no longer output a safe 1V output.

AVERTISSEMENT!

Après avoir mis l'interrupteur ON/OFF/P de l'onduleur monophasé sur ON, les câbles DC portent une haute tension et les optimiseurs de puissance ne génèrent plus la tension de sécurité de 1V.

When the inverter starts converting power after the initial connection to the AC, the inverter enters Wakeup mode until its working voltage is reached. This mode is indicated by the flickering green inverter LED.

When working voltage is reached, the inverter enters Production mode and produces power. The steadily lit green inverter LED indicates this mode.

4. Tap **OK** to return to the main menu.

Communication

Communication settings can be configured only after communication connections are complete. Refer to *Setting Up Communication* on page 66.

1. Select the **Communication** menu to define and configure the following:
 - The communication option used by the inverter to communicate with the monitoring platform
 - The communication option used to communicate between multiple SolarEdge devices or other external non-SolarEdge devices, such as electricity meters or loggers.
2. Tap the **Server** red arrow to set the communication method to be used for communication between devices and the SolarEdge monitoring platform. The default is LAN.

**NOTE**

The Server menu shows only the communication options installed in the inverter.

For detailed information about all the configuration options, refer to the *Communication Options Application Note*, available on the SolarEdge website at https://www.solaredge.com/sites/default/files/solaredge-communication_options_application_note_v2_250_and_above.pdf.



Power Control

Power control options are detailed in the *Power Control Application Note*, available on the SolarEdge website at .



The Grid Control option may be disabled. Enabling it opens additional options in the menu.

The Energy Manager option is used for setting power export limitation, as described in the *Export Limitation Application Note*, available on the SolarEdge website at https://www.solaredge.com/sites/default/files/export_limitation_application_note_NA.pdf.



For P(Q) diagram refer to https://www.solaredge.com/sites/default/files/application_note_p_q_diagram_of_se_inverters_en_and_na.pdf.



NOTE



SolarEdge inverters with “Grid Support” functionality (as marked on the inverter certification label), are compliant with UL 1741 Supplement A. The functionality is built into the inverter and no additional external device is required.

Device Manager

From the **Commissioning** menu, select **Device Manager** to configure various system Smart Energy Management devices.

For more information refer to <https://www.solaredge.com/products/device-control/#/>.



Maintenance

From the **Commissioning** menu, select **Maintenance** to configure various system settings, as described below.

- **Date and Time:** Set the internal real-time clock. If connected to the monitoring platform, the date and time are set automatically and only time zone should be set.
- **Reset Counters:** Resets the accumulated energy counters that are sent to the monitoring platform
- **Factory Reset:** Performs a general reset to the default device settings.
- **Arc Fault Circuit Interrupter (AFCI):** Enables or disables production interruption in case of arc-fault, sets the reconnection mode, and enables or disables manual AFCI self-test.

Refer to http://www.solaredge.com/sites/default/files/arc_fault_detection_application_note_na.pdf.

- **Firmware Upgrade:** Perform a software upgrade.
- **Diagnostics:** Displays the Isolation status and power optimizer status screens. Refer to https://www.solaredge.com/sites/default/files/application_note_isolation_fault_troubleshooting.pdf.

- **Activate Standby Mode:** Enables/disables Standby Mode - for remote commissioning.
- **Grid Protection:** Available in specific countries. Enables viewing and setting grid protection values.



- **Board Replacement:** Backs up and restores the system parameters, including energy counters; Used during board replacement according to the instructions supplied with replacement kits.

Information

From the **Commissioning** menu, select **Information** to view and set various system settings, as described below.

- **CPU Version:** The communication board firmware version
- **DSP 1/2 Version:** The digital board firmware version



NOTE

Please have these numbers ready when you contact SolarEdge Support.

- **Serial Number** - The inverter serial number as appears on the enclosure sticker
- **Hardware IDs:** Displays the following HW serial numbers (if exist, and connected to the inverter):
 - **This inverter:** the inverter's ID
 - **Meter # :** Energy meter ID (up to 3 meters can be connected)
 - **ZB:** ZigBee Plug-in MAC address
 - **Cell:** MEID (CDMA) or IMEI (GSM)
- **Error Log:** Displays the last five errors, and enables resetting (clearing) the log.
- **Warning Log:** Displays the last five warnings, and enables resetting (clearing) the log.

Step 3: Verifying Proper Activation and Commissioning

1. Select **Information** and verify that the correct firmware versions are installed on each inverter.
2. Select **Status** and verify that inverter is operating and producing power (see also *Viewing System Status* on page 57).
3. Verify that additional configurations were properly set by viewing the relevant Status screens.
4. Verify that the green inverter LED is steadily lit.

Your SolarEdge power harvesting system is now operational.

Viewing System Status

During normal operation, the **Status** screen displays all the inverter settings and operation status. Scroll up or down to display various status parameters as described in the following sections.

The LED indication provides more information about system performance; Refer to *LEDs* on page 30.

→ To access the Status screen:

From the **Commissioning** menu select **Status**. The main inverter Status screen is displayed (see below).

A red or orange icon (for example: ) may appear at the top left corner of a status cell, indicating an error. The color indicates error severity (red is top severity). The error description or information appears on the screen. Tap the error line for more information and troubleshooting instructions, and refer to *Errors and Troubleshooting* on page 79.

A gray clock icon () may appear at the top left corner of a status cell, indicating a temporary status, such as a connection process. When the process is complete, the icon disappears and a constant status message is displayed.

Main Inverter Status

solar edge		
Status		
Inverter		
SN 07318000C		
Power	Voltage	Frequency
50 kW	230Vac	50 Hz
🕒 P_OK: 15 of 20 Optimizers Connected	Server Comm. S_OK (LAN)	
Status Production	⚠️ Switch OFF	
CosPhi	Limit	Country
1.00	No Limit	USA2
Voltage	Temp	Fan
350 Vdc	156 F	N/A
⚠️ Switch Off. Production disabled >		
Commissioning >		

- **Inverter:** The inverter serial number
- **Power:** The AC output power
- **Voltage (Vac):** The AC output voltage
- **Frequency:** The AC output frequency
- **S_OK:** The connection to the monitoring platform. (**Server Connected** appears only if the inverter is connected to the monitoring platform).
- **Status:** The inverter operation status: Off, Not Paired, Night Mode, Error, Pairing, or Production
- **Switch:** Indicates the position of the inverter ON/OFF/P switch: On, Off, or P position.
- **CosPhi:** Indicates the ratio between active and reactive power. A negative value

indicates a lagging CosPhi.

For more information, refer to the *Power Control Application Note*, available on the SolarEdge website at https://www.solaredge.com/sites/default/files/application_note_power_control_configuration.pdf.



- **Limit:** The inverter maximum output power
- **Country:** The selected country and grid setting
- **Voltage (Vdc):** The DC input voltage
- **Temp (°C or °F):** The inverter heat sink temperature

Site Status

The Site status screen shows the accumulated status of all inverters connected to a master inverter in a chain (bus) and the master inverter status.

solar edge		
Status		
Site		
Production	Limit	Inverters
90 kW	1.00 MW	10/10
Inverter		
SN 07318000C		
Power	Voltage	Frequency
100 kW	277 Vac	60.9 Hz
P_OK: 31 Of 31	S_OK	
Optimizers Connected	Server Connected	
Status	⚠	Switch
Production		OFF
CosPhi	Limit	Country
1.00	Export	USA2
⚠ Switch Off. Production disabled >		
Commissioning >		

- **Site status:**
 - **Production:** The AC output power
 - **Limit:** Limitation setting (Export or Production)
 - **Inverters:** Number of connected inverters in the cluster, including the master.

Communication Status

This screen displays the status of connection option(s): LAN, RS485, cellular or ZigBee Plug-in.

Communication		
LAN Connected	RS485-1 SE Slave NC	RS485-2 Modbus 2 of 2
Cellular N/A		ZigBee NC

For each communication option, one of the following statuses is displayed:

- **Connected:** The inverter established a successful connection and communication with the specified server port
- **NC:** Not Connected. Refer to *Troubleshooting Communication* on page 81
- **S_OK:** The connection to the monitoring platform is successful (should appear only if the inverter is connected to the server)
- **N/A :** Not Applicable
- **x of y:** Number of devices connected out of all devices
- Temporarily displayed (with a ⌚ clock sign):
 - **Initializing communication**
 - **Connecting** to a network
 - **Connecting** to SolarEdge servers
- **Error message** (with the ⚠ sign). Refer to *Troubleshooting Communication* on page 81.

Inverter Energy Status

Displays the total energy produced during the last day, month, year and since inverter installation.

Inverter Energy		
Today	This Month	This Year
45 kWh	1.14 MWh	13.68 MWh
Total: 41.03 MWh		

- **Today:** since midnight
- **This Month:** since 1st of the current month
- **This Year:** since January 1st
- **Total (Wh):** The inverter total energy. If an external meter is installed, the value displayed in this line depends on the meter type connected to the inverter and its location:
 - If a bidirectional meter is connected at the consumption point, this value is the consumed energy.
 - If the meter is installed at the production point, this value is the energy produced by the site.
 - If the meter is installed at the grid connection point, this value is the energy exported to the grid.

Meter Status

Meters
Export – RS485-2 Modbus ID #2 Status: OK

- **Type and function:** Displays the meter functionality (Production, Export, Import, Export+Import)
- **Status:** Displays OK if the meter is communicating with the inverter
- **<Error message>:** If there is a meter error, it is displayed in this line.
- **Power:** Depending on the meter type connected to the inverter, this line displays the exported or imported power
- **Energy:** The total energy read by the meter. The value displayed in this line depends on the meter type connected to the inverter and its location:
 - If a bidirectional meter is connected at the consumption point, this value is the consumed energy.
 - If the meter is installed at the production connection point, this value is the energy produced by the site.
 - If the meter is installed at the grid connection point, this value is the energy exported to the grid.



NOTE

This data is accumulated according to an internal real-time clock.

Reporting and Monitoring Installation Data

NOTE



Monitoring the site requires connecting the inverter to the monitoring platform, using any of the wired or wireless options available from SolarEdge. Refer to *Setting Up Communication* on page 66.

The Monitoring Platform

The monitoring platform provides enhanced PV performance monitoring and yield assurance through immediate fault detection and alerts at the module, string and system level.

Using the platform, you can:

- View the latest performance of specific components.
- Find under-performing components, such as modules, by comparing their performance to that of other components of the same type.
- Pinpoint the location of alerted components using the physical layout.

The monitoring platform enables accessing site information, including up-to-date information viewed in a physical or logical view:

- **Logical Layout:** Shows a schematic tree-layout of the components in the system, such as: inverters, strings, modules, meters and sensors, as well as their electrical connectivity. This view enables you to see which modules are connected in each string, which strings are connected to each inverter, and so on.
- **Physical Layout:** Provides a bird's eye view of the actual placement of modules in the site, and allows pinpoint issues to the exact location of each module on a virtual site map.

If you do not report the mapping of the installed power optimizers, the monitoring platform will show the logical layout indicating which power optimizers are connected to which inverter, but will not show strings or the physical location of power optimizers.

The monitoring platform includes a built-in help system, that guides you through the monitoring functionality.

For more information, refer to <https://www.solaredge.com/products/pv-monitoring#/>.



Creating Logical and Physical Layout using Installation Information

To display a logical layout, insert the inverter serial number in the new site created in the monitoring platform. When the communication between the inverter and the monitoring server is established, the logical layout is displayed.

To display a physical layout, you need to map the locations of the installed power optimizers. To map the locations, use one of the methods described in the next sections.

Designer

Designer recommends inverter and power optimizer selection per site size and enables report generation. You can create a project in Designer and export the site design with the string layout to the monitoring platform.



For more information, refer to

<https://www.solaredge.com/products/installer-tools/designer#/>.

Mapper Application

Use the Mapper smart phone application to scan the power optimizer and inverter 2D bar-codes and create a virtual map of a PV site for enhanced monitoring and easier maintenance.

The Mapper application is integrated with the monitoring platform and enables:

- Simple on-site registration of new systems.
- Creating, editing and verifying system physical layout.
- Scanning and assigning the power optimizer serial number to the correct module in the system physical layout.

For detailed information, refer to the *Mapper* demo movies:

- [Creating new sites using the Mapper mobile application](#)
- [Mapping existing sites using the Mapper mobile application](#)



Physical Layout Editor

1. If you are a registered installer, access the monitoring platform site creation page at <https://monitoring.solaredge.com/solaredge-web/p/home#createSites>. If you have not yet signed up, go to <https://monitoring.solaredge.com/solaredge-web/p/createSelfNewInstaller>.
2. Fill out all required information in the screen, which includes information about your installation, as well as details about its logical and physical mapping.



Using a Paper Template

Fill out the Physical Layout Template (downloadable from the SolarEdge website <http://www.solaredge.com/files/pdfs/physical-layout-template.pdf>) using the detachable 2D barcode stickers on each power optimizer. Once the form is completed, use the Mapper to scan the 2D codes and create the map in the monitoring platform. Optionally, you can send the sticker sheet to SolarEdge Support for physical layout creation.



Chapter 6: Setting Up Communication

The inverter sends the following information to the monitoring platform:

- Power optimizer information received via the DC power lines (the PV output circuit).
- Inverter information
- Information of any other connected devices.

This chapter describes setting up communication between:

- The inverter and the monitoring platform through the Internet (wired/ wireless), or through a cellular connection.
- Multiple inverters for a master/slave configuration.

Communication setup is not required for power harvesting, however it is needed for using the monitoring platform.

CAUTION!



When connecting the communication cables, make sure that the ON/OFF switch on the Safety Switch is turned OFF, and the AC is turned OFF.

When configuring the communication parameters, make sure that the ON/OFF switch on the Safety Switch is OFF, and the AC is turned ON.

ATTENTION!

Lors de la connexion des câbles de communication, assurez-vous que l'interrupteur MARCHÉ/ARRÊT à la base de l'onduleur soit en position ARRÊT, et le CA est en position ARRÊT. Lors de la configuration des paramètres de communication, assurez-vous que l'interrupteur MARCHÉ/ARRÊT soit en position ARRÊT, et le CA est en position MARCHÉ.

Communication Options

The following types of communication can be used to transfer the monitored information from the inverter to the monitoring platform.

Only communication products offered by SolarEdge are supported.

Always connect the communication options when the relevant devices are powered down - Commercial Gateway, inverter, etc.

Ethernet

Ethernet is used for a LAN connection. For connection instructions refer to *Creating an Ethernet (LAN) Connection* on page 69.

RS485

RS485 is used for the connection of multiple SolarEdge devices on the same bus in a master-slave configuration. RS485 can also be used as an interface to external devices, such as meters and third party data loggers.

- RS485-1: Enables the connection of multiple devices (inverters/Commercial Gateway) over the same bus, such that connecting only one device to the Internet is sufficient to provide communication services for all the devices on the bus.
- RS485-2: Enables connection of multiple SolarEdge devices and of non-SolarEdge devices over the same bus.

Cellular (GSM, CDMA)

This wireless communication option (purchased separately) enables using a cellular connection to connect one or several devices (depending on the data plan used) to the monitoring platform.

The GSM/CDMA Plug-in is provided with a user manual, which should be reviewed prior to connection. Refer to

https://www.solaredge.com/sites/default/files/cellular_gsm_installation_guide_for_inverters_with_setapp.pdf

and https://www.solaredge.com/sites/default/files/cellular_cdma_installation_guide_for_inverters_with_setapp.pdf.



Communication Connectors

Two communication glands are used for connection of the various communication options. Each gland has three openings. The table below describes the functionality of each opening. Unused openings should remain sealed.

Gland#	Opening	Functionality	Cable size (diameter)
1 (PG16)	One small	External antenna cable	2-4 mm
	Two large	Ethernet connection (CAT5/6) or Cellular	4.5-7 mm
2 (PG13.5)	All three	RS485	2.5-5 mm

Figure 27: Communication Glands

The communication board has a standard RJ45 terminal block for Ethernet connection, and a 6-pin terminal block for RS485 connection, as shown below:

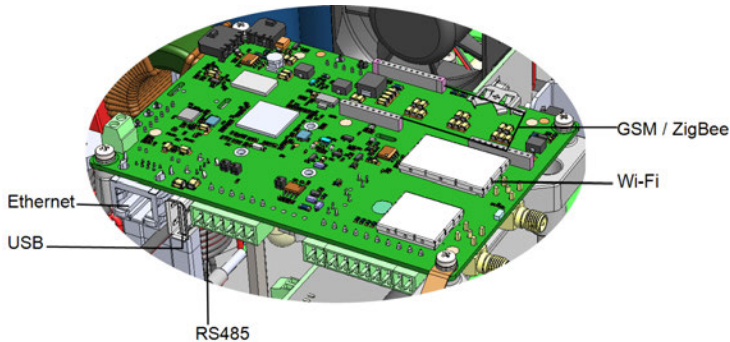

Figure 28: Internal connectors

Removing the Inverter Cover

If the inverter cover is not already removed, use the following procedure for cover removal.

→ To remove the inverter cover

1. Turn the inverter ON/OFF/P switch to OFF. Wait 5 minutes for the capacitors to discharge.
2. Turn the Safety Switch to OFF.
3. Disconnect the AC to the inverter by turning OFF the circuit breakers on the distribution panel.
4. Open the Allen screws of the inverter cover and carefully pull the cover horizontally before lowering it.

CAUTION!

When removing the inverter cover, make sure not to damage the internal components. SolarEdge will not be held responsible for any components damaged as a result of incautious cover removal.



ATTENTION!

Lors du retrait du couvercle, assurez-vous de ne pas endommager les composants internes. SolarEdge ne peut être tenue pour responsable des composants endommagés à la suite d'une imprudence dans le retrait du couvercle.

Creating an Ethernet (LAN) Connection

This communication option enables using an Ethernet connection to connect the inverter to the monitoring platform through a LAN.

Ethernet cable specifications:

- Cable type – a shielded Ethernet cable (Cat5/5E STP) may be used
- Maximum distance between the inverter and the router – 100 m/ 330 ft.

NOTE

If using a cable longer than 10 m / 33 ft in areas where there is a risk of induced voltage surges by lightning, it is recommend to use external surge protection devices.

For details refer to:

https://www.solaredge.com/sites/default/files/overvoltage_surge_protection_na.pdf





Figure 29: Example of Ethernet connection

→ To connect the Ethernet cable:

1. Remove the inverter cover as described in *Removing the Inverter Cover* on page 69.
2. Open the communication gland #1.



CAUTION!

The gland includes a rubber waterproof fitting, which should be used to ensure proper sealing.

ATTENTION!

Le cote interne du gland contient une rondelle qui doit être utilisée pour une bonne étanchéité.

3. Remove the plastic seal from one of the large opening .
4. Remove the rubber fitting from the gland and insert the CAT5/6 cable through the gland and through the gland opening in the inverter .
5. Push the cable into the cut opening of the rubber fitting.

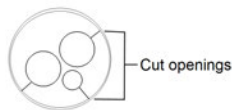

Figure 30: Rubber fitting

CAT5/6 standard cables have eight wires (four twisted pairs), as shown in the diagram below. Wire colors may differ from one cable to another. You can use either wiring standard, as long as both sides of the cable have the same pin-out and color-coding.

RJ45 Pin #	Wire Color ⁽¹⁾		10Base-T Signal 100Base-TX Signal
	T568B	T568A	
1	White/Orange	White/Green	Transmit+
2	Orange	Green	Transmit-
3	White/Green	White/Orange	Receive+
4	Blue	Blue	Reserved
5	White/Blue	White/Blue	Reserved
6	Green	Orange	Received-
7	White/Brown	White/Brown	Reserved
8	Brown	Brown	Reserved

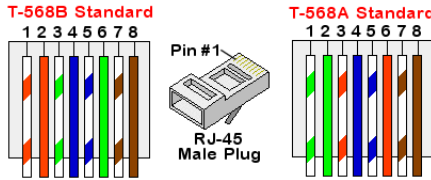

Figure 31: Standard cable wiring

6. Use a pre-crimped cable to connect via gland #1 to the RJ45 plug on the inverter's communication board or, if using a spool of cable, connect as follows:
 - a. Insert the cable through gland #1.
 - b. Remove the cable's external insulation using a crimping tool or cable cutter and expose eight wires.
 - c. Insert the eight wires into an RJ45 connector, as described in *Figure 31*.
 - d. Use a crimping tool to crimp the connector.
 - e. Connect the Ethernet connector to the RJ45 port on the communication board.

(1)The inverter connection does not support RX/TX polarity change. Supporting crossover Ethernet cables depends on the switch capabilities.

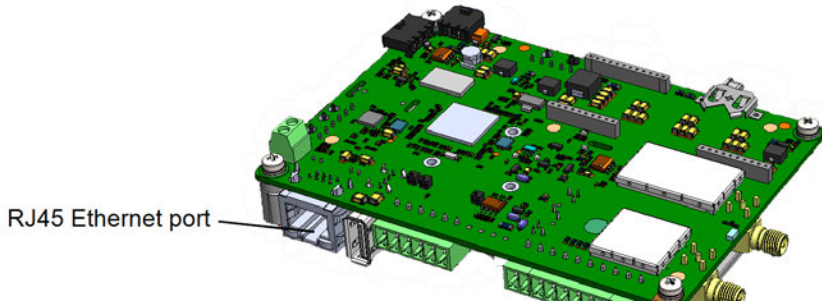

Figure 32: The RJ45 Ethernet connection

7. For the switch/router side, use a pre-crimped cable or use a crimper to prepare an RJ45 communication connector: Insert the eight wires into the RJ45 connector in the same order as above (*Figure 31*).
8. Connect the cable RJ45 connector to the RJ45 port of the Ethernet switch or router. You can connect more than one inverter to the same switch/router or to different switches/routers, as needed. Each inverter sends its monitored data independently to the monitoring platform.
9. The inverter is configured by default to LAN. If reconfiguration is required:
 - a. Make sure the ON/OFF/P switch is OFF.
 - b. Turn ON the AC to the inverter by turning ON the circuit breaker on the main distribution panel.
 - c. Configure the connection as described in *Communication* on page 53.

NOTE

If your network has a firewall, you may need to configure it to enable the connection to the following address:



- Destination Address: prod2.solaredge.com
- TCP Port: 22222, 22221, or 80 (for incoming and outgoing data)

10. Verify the connection, as described in *Verifying the Connection* on page 77.

Creating an RS485 Bus Connection

The RS485 option enables creating a bus of connected inverters, consisting of up to 31 slave inverters and 1 master inverter. Using this option, inverters are connected to each other in a bus (chain), via their RS485 connectors. The first and last inverters in the chain must be terminated as described on page 75.

RS485 wiring specifications:

- Cable type: Min. 3-wire shielded twisted pair (a shielded Ethernet cable (Cat5/5E STP) may be used)
- Wire cross-section area: 0.2- 1 mm²/ 24-18 AWG (a CAT5 cable may be used)
- Maximum nodes: 32
- Maximum distance between first and last devices: 1 km /3300 ft.

NOTE

If using a cable longer than 10 m/33 ft in areas where there is a risk of induced voltage surges by lightning, it is recommend to use external surge protection devices. For details refer to:

https://www.solaredge.com/sites/default/files/overvoltage_surge_protection_na.pdf.



If grounded metal conduit are used for routing the communication wires, a lightning protection device is not required.

If not using surge protection, connect the grounding wire to the first inverter in the RS485 chain; ensure it is not in contact with other wires. Connect the grounding wire to the grounding bus-bar in the Safety Switch.

The following sections describe how to physically connect the RS485 bus and how to configure the bus.

→ **To connect the RS485 communication bus:**

1. Remove the inverter cover as described in *Removing the Inverter Cover* on page 69.
2. Remove the seal from one of the openings in communication gland #2 and insert the wire through the opening.

3. Pull out the 6-pin RS485 terminal block connector, as shown below:

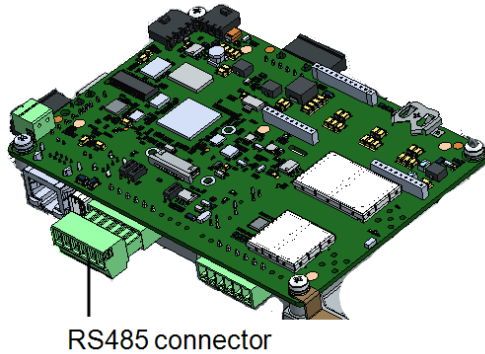

Figure 33: The RS485 terminal block

4. Loosen the screws of pins A(+), B(-), and G on the left of the RS485 terminal block (RS485-1 or RS485-2).

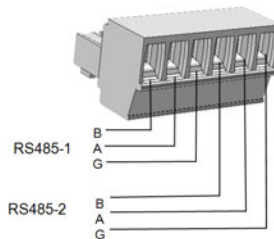

Figure 34: RS485 terminal block

5. Insert the wire ends into the **G**, **A** and **B** pins shown above. Use Four- or six-wire twisted pair cable for this connection.

You can use any color wire for each of the **A**, **B** and **G** connections, as long as:

- The same color wire is used for all A pins the same color for all B pins and the same color for all G pins
- The wire for G is not from the same twisted pair as A or B.

- For creating an RS485 bus - connect all B, A and G pins in all inverters. The following figure shows this connection schema:

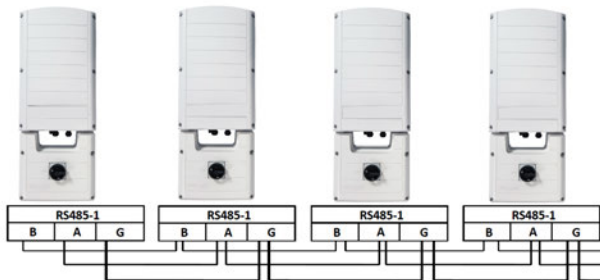

Figure 35: Connecting the inverters in a chain



NOTE

Do not cross-connect B, A and G wires.

- Tighten the terminal block screws.
- Check that the wires are fully inserted and cannot be pulled out easily.
- Push the RS485 terminal block firmly all the way into the connector on the right side of the communication board.
- Terminate the first and last SolarEdge device in the chain by switching a termination DIP-switch inside the inverter to ON (move the left switch up). The switch is located on the communication board and is marked SW7SW1.

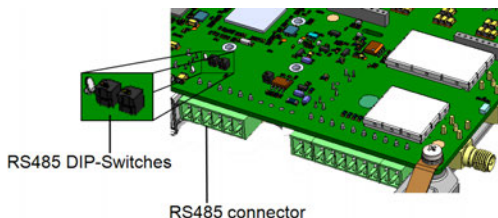

Figure 36: RS485 termination switch

NOTE



Only the first and last SolarEdge devices in the chain should be terminated. The other inverters in the chain should have the termination switch OFF (down position).

- If not using surge protection, connect the grounding wire to the first inverter in the RS485 chain; make sure the grounding wire is not in contact with other wires. For inverters with a Safety Switch, connect the grounding wire to the grounding bus-bar in the Safety Switch.

→ **To connect to the monitoring platform:**

1. Designate a single inverter as the connection point between the RS485 bus and the monitoring platform. This inverter will serve as the master inverter.

→ **To configure the RS485 bus:**

All inverters are configured by default as slaves. To configure the master:

1. Verify the ON/OFF/P switch is OFF.
2. Verify that AC is on.
3. Use SetApp to access the **Commissioning** menu screen as described in *Communication* on page 53.
4. From the **Commissioning** menu tap **Communication**. The Communication screen is displayed.
5. Select the following to configure the connection:
 - Server → **LAN**
 - RS485-1 → Protocol → **SolarEdge Master**
 - RS485-1 → **Slave Detect**

The system starts automatic detection of the slave inverters connected to the master inverter. The inverter should report the correct number of slaves. If it does not, verify the connections and terminations.

6. To check the slave IDs and last communication time, select **RS485-1 → Slave List**.
7. Verify the connection of the master to the monitoring platform, as described in the next section.

Verifying the Connection

After connecting and configuring a communication option, perform the following steps to check that the connection to the monitoring server has been successfully established.

1. Access the Status screen:
 - a. If not already ON - turn ON AC to the inverter by turning ON the circuit breaker on the main distribution panel.
 - b. Open SetApp and follow the instructions on the screen (scan the inverter bar-code; move the ON/OFF/P switch to P position (for less than 5 sec) and release). The mobile device creates a Wi-Fi connection with the inverter and displays the main Commissioning screen.

solar ^{edge}		
Status		
Inverter		
SN 07318000C		
Power	Voltage	Frequency
Optimizers Connected	S_OK Server Connected	
Status	Switch	
Production	ON	
CosPhi	Limit	Country
1.00	No Limit	USA2
Voltage	Temp	Fan
Commissioning		

2. Check that **S_OK - Server Connected** status appears in the main inverter section.
3. Scroll down to the Communication section and check that the communication options are as required. For more information refer to *Communication Status* on page 60.

Communication		
LAN Connected	RS485-1 SE Slave NC	RS485-2 Modbus 2 of 2
Cellular N/A	ZigBee NC	

Appendix A: Errors and Troubleshooting

This appendix describes general system problems, and how to troubleshoot them. For further assistance, contact SolarEdge Support.

Identifying Errors

Errors may be indicated in various system interfaces: On the inverter bottom panel, a red LED indicates an error. In the monitoring platform and the SetApp, errors are displayed with codes.

For more information on the codes displayed for error and warning messages, refer to https://www.solaredge.com/sites/default/files/troubleshooting_for_se_inverter_insallation_guide_addendum_na.pdf. This document describes errors that appear in SetApp, monitoring platform, and LCD (for inverters with LCD).



To identify the error types, use the methods described below.

→ To identify the error type using the inverter LEDs:

1. Move the ON/OFF/P switch to **P** position for **less** than 5 seconds and release it.
2. Observe the LED lights and use the following table to identify the error type. For more information, refer to <https://www.solaredge.com/us/leds>.



Error type	LED color and state		
	Red	Green	Blue
Arc detected	ON	OFF	OFF
Isolation or RCD problem	Blinking	OFF	OFF
Grid error	OFF	ON	OFF
High temperature	OFF	Blinking	OFF
Pairing failed	OFF	OFF	ON
Other issue	OFF	OFF	Blinking

→ To identify the error type using the monitoring platform:

1. Open the site dashboard and click the **Layout** icon.
2. Right-click the inverter and select **Info** from the menu (*Figure 37*). The inverter details window is displayed (*Figure 38*).

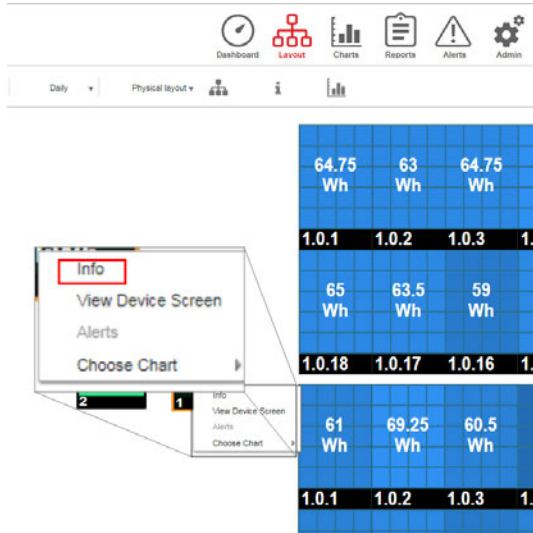

Figure 37: Inverter menu

3. Click the **Errors** tab. The list is displayed.

Details for Inverter 1

System data Running operations Device screen **Errors**

Your last refresh: 10/18/2017 10:32 AM Refresh

Code	QTY	Description	Last Occurrence	
119	1	INIT	10/10/2017 07:55	>
61	1	AC Voltage Too Low (Line 1)	09/20/2017 14:32	>
63	1	AC Voltage Too Low (Line 2)	09/20/2017 14:32	>

Figure 38: Inverter details - Error list

Troubleshooting Communication

Troubleshooting Ethernet (LAN) Communication

The possible errors and their troubleshooting are detailed in the following table:

Error Message	Cause and Troubleshooting
LAN cable disconnected	Physical connection fault. Check the cable pin-out assignment and cable connection
No DHCP	IP settings issue. Check the router and inverter configuration. Consult your network IT.
Configure Static IP or set to DHCP	
Gateway not responding	Ping to router failed. Check the physical connection to the switch/ router. Check that the link LED at the router /switch is lit (indicating phy-link). If OK - contact your network IT, otherwise replace the cable or change it from cross to straight connection.
No Internet connection	Ping to google.com failed. Connect a laptop and check for internet connection. If internet access is unavailable, contact your IT admin or your internet provider.
No connection to SolarEdge servers	Ping or connection to SolarEdge server failed. Check the SolarEdge server address, under LAN Conf sub-menu: Address: prod.solaredge.com Port: 22222 Check with your network administrator whether a firewall or another device is blocking transmission.

Troubleshooting RS485 Communication

- If the message **RS485 Master Not Found** appears in the Status screen, check the connections to the master device and fix if required.
- If after slave detection the number of slaves displayed for the master under **RS485-X Conf → Slave Detect** is lower than the actual number of slaves, refer to the following application note to identify missing slaves and troubleshoot connectivity problems: https://www.solaredge.com/sites/default/files/troubleshooting_undetected_RS485_devices.pdf



Additional Troubleshooting

1. Check that the modem or hub/router is functioning properly.
2. Check that the connection to the internal connector on the communication board is properly done.
3. Check that the selected communication option is properly configured.
4. Use a method independent of the SolarEdge device to check whether the network and modem are operating properly. For example, connect a laptop to the Ethernet router and connect to the Internet.
5. Check whether a firewall or another type of network filter is blocking communication.

Power Optimizer Troubleshooting

Problem	Possible cause and troubleshooting
Pairing failed	Power optimizers are shaded. If you connected the inverter to the monitoring platform, retry pairing remotely (during sunlight). Make sure to leave the inverter ON/OFF switch ON and that S_OK appears in the status screen.
String voltage is 0V	Power optimizer (s) output is disconnected. Connect all power optimizer outputs.
String voltage not 0V but lower than number of optimizers	Power optimizer(s) not connected in the string. Connect all power optimizers
	Module(s) not connected properly to power optimizer inputs (not applicable to smart modules). Connect the modules to the optimizer inputs
	String reverse polarity. Check string polarity using a voltmeter and correct if needed.

Problem	Possible cause and troubleshooting
<p>String voltage is higher than number of optimizers</p> <p>WARNING! If the measured voltage is too high, the installation may not have a safe low voltage. PROCEED WITH CARE! A deviation of $\pm 1\%$ per string is reasonable.</p> <p> AVERTISSEMENT! <i>Si la tension mesurée est trop haute, la tension basse de sécurité pourrait manquer dans l'installation. REDOUBLEZ DE PRECAUTION. Une déviation de $\pm 1\%$ par string est raisonnable.</i></p>	<p>Extra power optimizer(s) connected in the string (not applicable to smart modules).</p> <p>Check if an extra power optimizer is connected in the string. If not – proceed to next solution.</p> <p>A module is connected directly to the string, without a power optimizer (not applicable to smart modules).</p> <p>Verify that only power optimizers are connected in the string and that no module outputs are connected without a power optimizer. If the problem persists, proceed to the next step.</p> <p>Power optimizer(s) malfunction.</p> <ol style="list-style-type: none"> 1. Disconnect the wires connecting the power optimizers in the string. 2. Measure the output voltage of each power optimizer to locate the power optimizer that does not output 1V safety voltage. If a malfunctioning power optimizer is located, check its connections, polarity, module, and voltage. 3. Contact SolarEdge Support. Do not continue before finding the problem and replacing the malfunctioning power optimizer. If a malfunction cannot be bypassed or resolved, skip the malfunctioning power optimizer, thus connecting a shorter string.

Appendix B: Mechanical Specifications

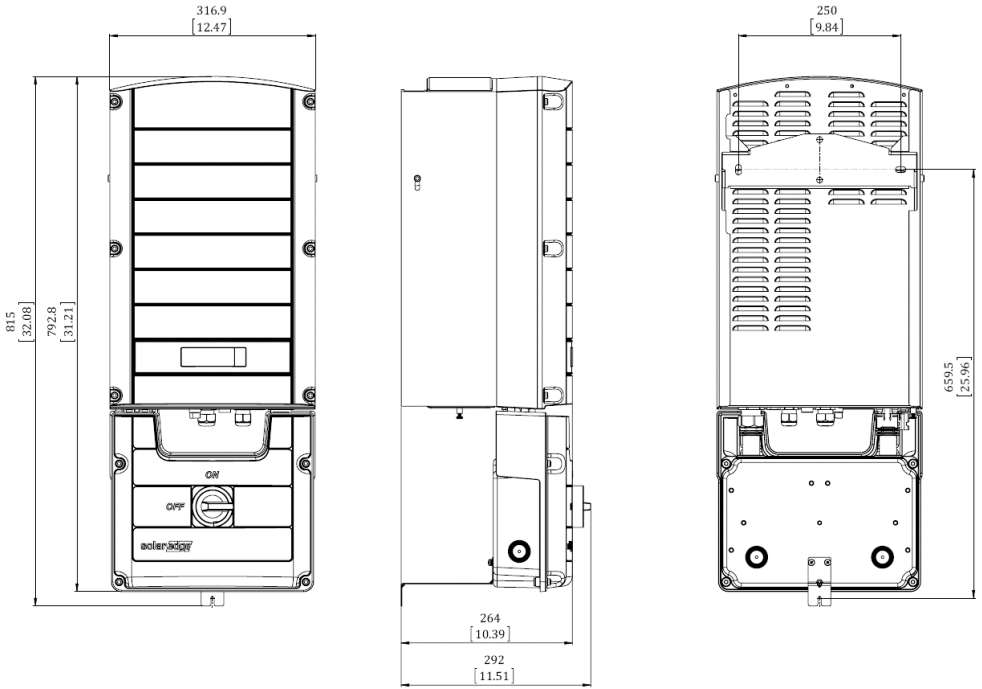

Figure 39: Three phase inverter with bracket - front, side and rear views

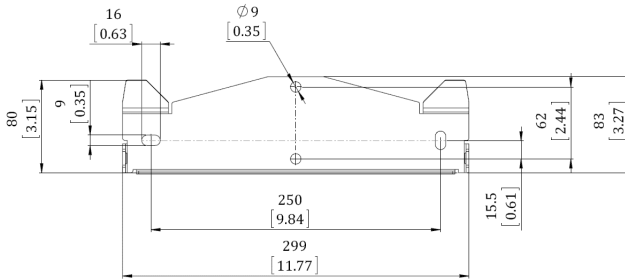

Figure 40: Inverter mounting bracket

Appendix C: External Fan Maintenance and Replacement

The inverter has two fans: one is internal and the other is accessible from the outside of the inverter.

A fan replacement kit is available from SolarEdge.

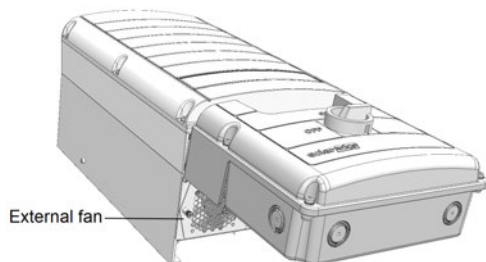

Figure 41: Inverter external fan

Fan Maintenance

At least once a year, open the fan screen and clean the accumulated dust using a brush.

If the SetApp Status screen displays the status **Not Working** for the fan (refer to *Main Inverter Status* on page 58), replace the fan as described in the next section.

External Fan Replacement

1. Turn OFF the inverter ON/OFF/P switch, and wait until the green LED is blinking, indicating that the DC voltage is safe (<50V), or wait five minutes before continuing to the next step.
2. Turn OFF the Safety Switch.
3. Disconnect the AC to the inverter by turning OFF the circuit breakers on the distribution panel.
4. Use a standard screwdriver to unfasten the two screws of the fan cover and open the fan door.

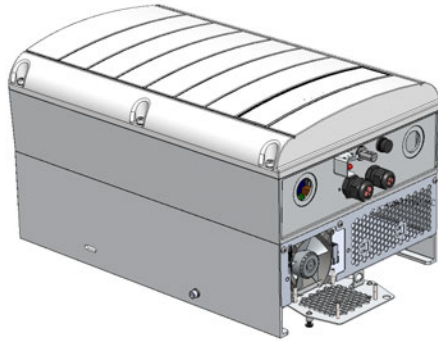
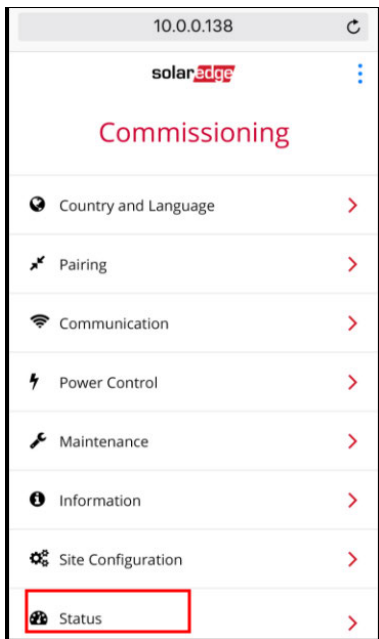

Figure 42: Fan door open

5. Disconnect the fan connector and remove the fan.
6. Connect the fan connector to the new fan.
7. Close the fan door and fasten the cover screws.

1. After powering up the inverter, check the fan status on SetApp: Select **Commissioning** → **Status**.



Status		
Inverter SN 07318000C		
Power 7.60 kW	Voltage 240 V _{ac}	Frequency 60.9 Hz
P_OK: 30 of 30 Optimizers Connected		S_OK Server Connected (LAN)
Status Production		Switch ON
Cos Phi 1.00	Limit No Limit	Country USA2
Voltage 380 V _{dc}	Temp. 156 F	Fan OK

Appendix D: Replacing and Adding System Components

This appendix includes replacement procedures for the SolarEdge system components. For inverter or Safety Switch replacement, typically only the part to be replaced is supplied (not both inverter and Safety Switch). In this case, the Safety Switch should be disconnected from the inverter as described herein.

NOTE



If you are permanently disassembling the installation or part of it, make sure to use the disposal methods dictated by local regulations.

CAUTION!

Do not remove the six screws on the DC conduit metal panel as it may harm the inverter sealing and void the warranty.



ATTENTION!

Ces vis ne doivent pas être retirées. Les enlever est susceptible d'endommager l'étanchéité de l'onduleur et annuler la validité de la garantie.

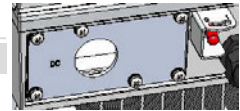

Replacing an Inverter

1. Turn OFF the Safety Switch (if applicable).
2. Turn OFF the inverter ON/OFF/P switch, and wait until the green LED is blinking, indicating that the DC voltage is safe (<50V), or wait five minutes before continuing to the next step.
3. Disconnect the AC to the inverter by turning OFF the circuit breakers on the distribution panel.
4. Open the inverter cover as described in *Removing the Inverter Cover* on page 69.
5. Disconnect the DC and AC wires from the inverter. If there are ferrite beads on the DC and AC wires in the inverter, open the beads and set them aside.
6. Unscrew the two conduit nuts in the inverter securing the Safety Switch to the inverter.

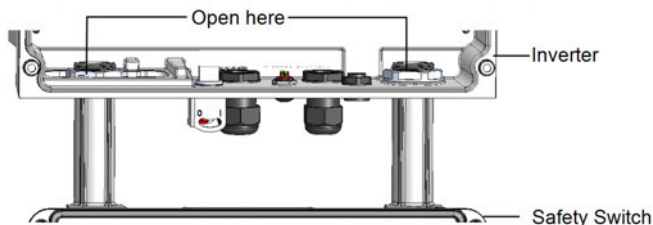

Figure 43: Conduit nuts

7. Remove the screws securing the inverter to the mounting bracket and remove the inverter from the mounting bracket.

NOTE

If you remove the old inverter and do not immediately install a new one, then:



- Lock the Safety Switch in the OFF position using a lock on the switch.
- Use insulation tape to isolate each of the AC and DC wires.
- Seal the open conduits using duct tape.

8. Place the new inverter on the mounting bracket; insert the screws securing the inverter to the mounting bracket.
9. Screw the two conduit nuts in the inverter securing the Safety Switch to the inverter.
10. Connect the DC and AC wires to the inverter.
11. If ferrite beads were removed from the DC and AC wires, place them on the wires and close them. Make sure the DC labeled ferrite bead is placed on the DC wires and the AC labeled ferrite bead is placed on the AC wires.
12. Close the Safety Switch cover and the inverter cover.
13. Perform the commissioning steps as described in *Activating, Commissioning and Configuring the System Using the Inverter SetApp* on page 51.

Replacing the Safety Switch

Removing the Safety Switch

1. Turn OFF the inverter ON/OFF/P switch, and wait until the green LED is blinking, indicating that the DC voltage is safe (<50V), or wait five minutes before continuing to the next step.

2. Turn OFF the Safety Switch and the AC breaker of the distribution panel.
3. Open the inverter cover.
4. Disconnect the DC and AC wires from the inverter. If there are ferrite beads on the DC and AC wires in the inverter, open them and set aside.
5. Unscrew the two conduit nuts in the inverter securing the Safety Switch to the inverter, as shown below:

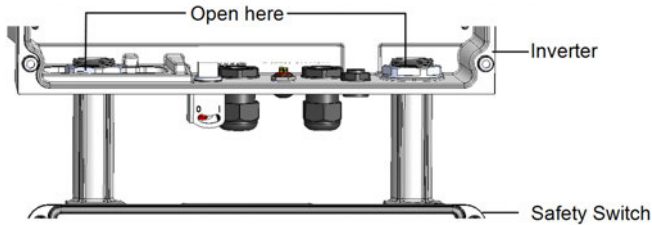

Figure 44: Disconnecting the conduits

6. Open the Safety Switch cover and disconnect the DC and AC wires. Unscrew the two conduit nuts securing the Safety Switch to the external conduits.
7. If the Safety Switch bracket is screwed to the wall, release it.
8. Carefully remove the Safety Switch with its mounting bracket from the wall.

Installing a New Safety Switch

1. Open the conduit drill guides of the new Safety Switch (refer to *Opening Conduit Drill Guides* on page 34).
2. Position the new Safety Switch below the inverter and from the inside of the inverter grab the AC and DC wires extending from the switch conduits.
3. Attach the Safety Switch with its bracket to the wall and slightly close the screws. Do not over tighten.
4. Securely screw the two conduit nuts onto the conduit ends in the inverter. Verify proper conduit sealing.

Connecting the Safety Switch to the Inverter

1. If ferrite beads were removed from the DC and AC wires, place them on the wires and close them. Make sure the DC labeled ferrite bead is placed on the DC wires and the AC labeled ferrite bead is placed on the AC wires.
2. Connect the DC, as follows:

- Connect the red wire to any of the DC+ terminals in the inverter.
- Connect the black wire to any of the DC- terminals in the inverter.

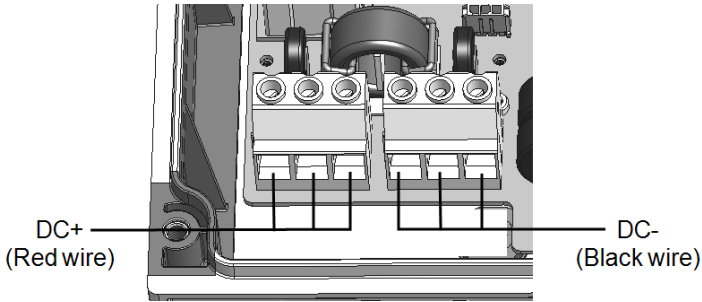

Figure 45: DC terminals

3. Connect the AC wires according to the labels on the AC terminal blocks, as follows:

Wire type	Connect to terminal
Line 1	L1
Line 2	L2
Line 3	L3
PE (grounding)	
Neutral	N

Figure 46: AC terminals

4. Tighten the screws of each terminal with a torque of 0.88-1.1 lb.*ft / 1.2-1.5 N*m.
5. Verify that there are no unconnected wires at the output of the Safety Switch and that any unused terminal screws are tightened.
6. Connect the DC and AC wires to the Safety Switch. Refer to *Connecting the AC and the Strings to the Safety Switch* on page 41.
7. Ensure proper conduit sealing; inspect the entire conduit run and use standard conduit sealants to avoid water penetration.

Adding, Removing, or Replacing Power Optimizers

1. Turn OFF the inverter ON/OFF/P switch, and wait until the green LED is blinking , indicating that the DC voltage is safe (<50V), or wait five minutes before continuing to the next step.
2. Disconnect the AC to the inverter by turning OFF the circuit breakers on the distribution panel.
3. Turn OFF the Safety Switch .
4. Disconnect and connect the necessary power optimizers.
5. Perform pairing and other procedures described in *Activating, Commissioning and Configuring the System Using the Inverter SetApp* on page 51 on all inverters to which power optimizers were added or from which power optimizers were removed.
6. In the monitoring platform, use the **Replace** button in the **logical layout** tab (in site Admin). Replace the serial number of the removed power optimizer with the serial number of the newly installed power optimizer. Refer to <https://www.solaredge.com/sites/default/files/se-monitoring-portal-site-admin.pdf>



Appendix E: Determining the Circuit Breaker Size

Revision History

- Version 1.0 February 2019: first release

Introduction

Inverters should be protected by circuit breakers. This document describes how to determine which circuit breaker to use in three phase commercial installations.

Using Transformers in Commercial Three Phase Inverter Installations

Using transformers in a commercial installation is optional. In most cases a transformer is used to connect the installation to the medium voltage power grid. The following figure illustrates a typical transformer and commercial three phase inverter installation topology.

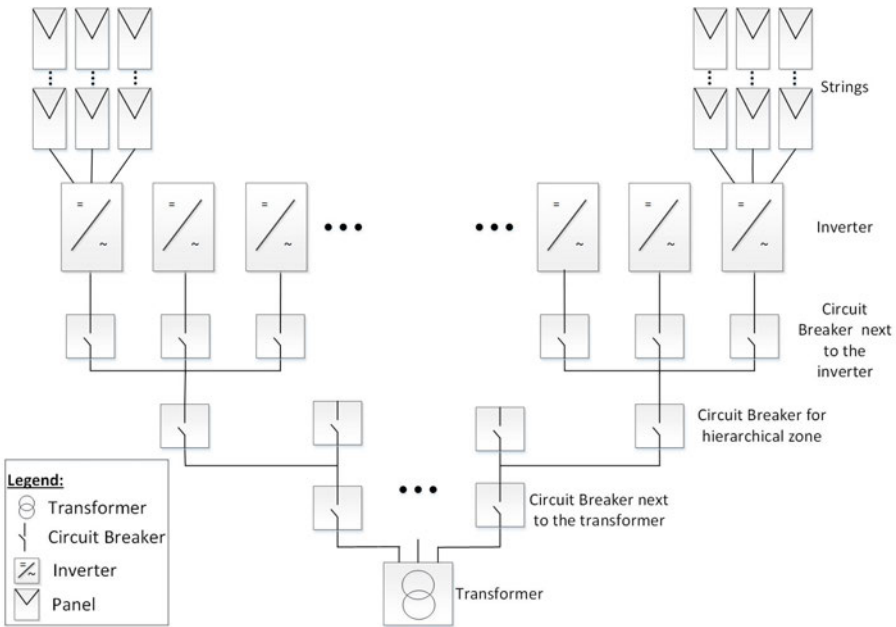

Figure 47: Typical transformer and commercial three phase inverter installation topology

There are many considerations for selecting the suitable transformer and its associated current limiting devices such as circuit breakers and fuses. The considerations must include at least the following:

- The transformer should be designed for a typical PV system production profile: high daytime loads with no loads at night.
- The current limiting devices should protect the electrical circuits and the inverters from the excess current created by an overload, or a short circuit. If a short circuit or other overcurrent occurs, the current limiting devices should block the current flow to the circuit, thus preventing damage to the electrical circuits and the inverters.

The circuit breakers and the fuses should comply with the transformer manufacturer recommendations and with the relevant sections in standards such as IEC 60909, IEC 60364, UL 508A and NEC 2017.

Some manufacturers provide detailed information about the transformer short circuit calculation procedure, and its effect on the selection of circuit breakers and fuses at the different hierarchical levels of the installation topology (see *Figure 47*).

For an example of a calculation, refer to:

- [Guidelines on the Short Circuit Current Rating for Industrial Control Panels](#)
- [Short-circuit current rating \(SCCR\) of industrial control panels](#)
- To ensure that the circuit breaker and fuses trip as expected, follow their manufacturers' recommendations, especially with respect to the various de-rating considerations.

NOTE



Transformer procurement, installation, maintenance and support are the responsibility of the installer. Damage to the inverter due to incorrect transformer installation, or use of a transformer that is incompatible with the SolarEdge system will render the SolarEdge warranty invalid.

NOTE



Transformer procurement, installation, maintenance and support are the responsibility of the installer. Damage to the inverter due to incorrect transformer installation, or use of a transformer that is incompatible with the SolarEdge system will render the SolarEdge warranty invalid.

Determining the Size of an Inverter Circuit Breaker

This section explains how to determine the rate of a circuit breaker next to an inverter. For an example of an inverter with a circuit breaker next to it see *Figure 47*.

Ensure you have the following parameters before determining the circuit breaker size:

- The inverter's maximum continuous output current as appears in the datasheet.
- Factor for the installation's country. This factor is dictated by regulation, applicable standards or common practice and is usually 1.25.

→ To determine the size of an inverter circuit breaker:

1. Multiply the inverter's maximum continuous output current by the factor.
For example, $40A \times 1.25 = 50A$
2. Round up the rated size, as calculated in step 1, to the closest standard circuit breaker size. See Circuit Breaker Criteria table below for standard sizes suitable for SolarEdge three phase inverters.



NOTE

If the result has a decimal fraction smaller than 0.5 round it down.

3. To ensure that the selected circuit breaker trips as expected, at minimum consider the following:
 - The circuit breaker rated voltage.
 - Temperature de-rating due to both close proximity of other circuit breakers and the effect of ambient temperature on the distribution board.
 - De-rating due to permanent load.

If the de-rated current of the selected circuit breaker is lower than the maximum output current of the inverter, consider selecting a circuit breaker that is designed for a higher rated current, or reducing the temperature de-rating effect by increasing the distance between adjacent circuit breakers.

NOTE



- Make sure to select cables that are suitable for the environmental conditions, the operating voltage and the selected circuit breaker.
- Three or four pole circuit breakers are required. It is recommended to use a four pole circuit breaker when applicable.
- It is recommended to use a circuit breaker with tripping characteristic B or C.

Table 1: Circuit Breaker Criteria

Inverter	Max. Continuous Output Current (per Phase)	Recommended Circuit Breaker
SE12.5K	20A	25A
SE14.4KUS	40A	50A
SE15K	23A	32A
SE16K	25.5A	32A
SE17K	26A	32A
SE25K	38A	50A
SE27.6K	40A	50A
SE30K	36.5A	50A
SE33.3K	40A	50A
SE43.2KUS	120A	150A
SE50K	76A	100A
SE55K	80A	100A
SE66.6K	80A	100A
SE66.6KUS	80A	100A
SE75K	120A	150A
SE82.8K	120A	150A
SE100K	120A	150A
SE100KUS	120A	150A

Technical Specifications - Three Phase Inverters (North America)

	SE9KUS	SE10KUS	SE14.4KUS	SE20KUS	SE30KUS	SE33.3KUS	Units
Supported grid	120 / 208	277 / 480	120 / 208	277 / 480			
OUTPUT							
Rated AC power output	9000	10000	14400	20000	30000	33300	VA
Maximum AC power output	9000	10000	14400	20000	30000	33300	VA
AC Output Line Connections	3 Phase, 3-wire / PE (L1-L2-L3), TN, TT 3 phase, 4-wire / PE (L1-L2-L3-N), TN, TT	3 phase, 4-wire / PE (L1-L2-L3-N), TN, TT	3 Phase, 3-wire / PE (L1-L2-L3), TN, TT 3 phase, 4-wire / PE (L1-L2-L3-N), TN, TT	3 phase, 4-wire / PE (L1-L2-L3-N), TN, TT			
AC output voltage minimum-nominal-maximum (L-N) ⁽¹⁾	105-120-132.5	244-277-305	105-120-132.5	244-277-305	244-277-305	244-277-305	Vac
AC output voltage minimum-nominal-maximum (L-L) ¹	183-208-229	422.5-480-529	183-208-229	422.5-480-529	422.5-480-529	422.5-480-529	Vac
AC frequency min-nom-max ¹	59.3 - 60 - 60.5 (with HI country setting 57 - 60 - 60.5)						Hz
Max. continuous output current (per Phase)	25	12	40	24	36.5	40	A
Max. output fault current and duration	73 / 150	51 / 150	92 / 150	73 / 150	88 / 150	92 / 150	A / mS
Inrush current AC (Peak / Duration)	2.6/20			4 / 20	4.2 / 20	4.2 / 20	Aac(rms) / ms
Max. back-feed current	0						A
Power factor range	1 (adjustable from -0.8 to +0.8)						
GFDI threshold	1						A
Total harmonic distortion	< 3						%
Utility monitoring, islanding protection, country configurable set points	Yes						
INPUT							
Maximum DC power	12150	13500	19400	27000	40500	45000	W
Transformer-less, ungrounded	Yes						
Maximum input voltage DC to Gnd	250	490	300	490	490	490	Vdc
Maximum input voltage DC+ to DC-	500	980	600	980	980	980	Vdc
Nominal input voltage DC to Gnd	200	420	200	420	420	420	Vdc
Nominal input voltage DC+ to DC-	400	840	400	840	840	840	Vdc
Maximum input current	26.5	13.5	38	26.5	39	40	Adc
Maximum short circuit current	45						Adc
Reverse-polarity protection	Yes						
Ground-fault isolation detection	1 M Sensitivity	1 M Sensitivity	350 k Sensitivity ⁽²⁾	1 M Sensitivity	350 k Sensitivity ¹	350 k Sensitivity ¹	
Maximum inverter efficiency	97.1	98.2	97	98.1	98.5	98.5	%
CEC weighted efficiency	96.5	98	97	98	98.5	98.5	%
Night-time power consumption	< 3	< 3	< 4	< 3	< 4	< 4	W

⁽¹⁾For other regional settings please contact SolarEdge Support.

⁽²⁾Where permitted by local regulations

	SE9KUS	SE10KUS	SE14.4KUS	SE20KUS	SE30KUS	SE33.3KUS	Units	
ADDITIONAL FEATURES								
Supported communication interfaces	2 x RS485, Ethernet, Built-in GSM (Optional)							
Inverter Commissioning	With the SetApp mobile application using built-in Wi-Fi station for local connection							
Rapid Shutdown – NEC 2014 and 2017 690.12	Automatic Rapid Shutdown upon AC grid disconnect ⁽¹⁾							
RS485 Surge Protection	Supplied with the inverter							
Smart Energy Management	Export Limitation							
STANDARD COMPLIANCE								
Safety	UL1741, UL1741 SA, UL1699B, CSA 22.2, Canadian AFCL according to T.I.L. M-07							
Grid connection standards	IEEE1547, Rule 21, Rule 14 (HI)							
Emissions	FCC part15 class B							
RoHS	Yes							
INSTALLATION SPECIFICATIONS								
AC output conduit size / AWG range	3/4" minimum / 12-6 AWG	3/4" minimum / 12-6 AWG	3/4" minimum / 8-4 AWG	3/4" minimum / 12-6 AWG	3/4" minimum / 8-4 AWG	3/4" minimum / 8-4 AWG		
DC input conduit size / # of inputs/ AWG range	3/4" minimum / 12-6 AWG							
Number of DC inputs	2 pairs		3 pairs (with fuses on plus & minus) ⁽²⁾	2 pairs	3 pairs (with fuses on plus & minus) ¹	3 pairs (with fuses on plus & minus) ¹		
Dimensions (HxWxD)	21 x 12.5 x 10.5 / 540 x 315 x 260							in/mm
Dimensions with Safety Switch (HxWxD)	30.5 x 12.5 x 10.5 / 775 x 315 x 260							in/mm
Weight	73.2 / 33.2	73.2 / 33.2	99.5 / 45	73.2 / 33.2	99.5 / 45	99.5 / 45	lb/kg	
Weight with Safety Switch	79.7 / 36.2	79.7 / 36.2	106 / 48	79.7 / 36.2	106 / 48	106 / 48	lb/kg	
Cooling	Fans (user replaceable)							
Noise (typical)	< 50		< 55	< 50	< 55	< 55	dBA	
Operating temperature range ⁽³⁾	-40 to +140 / -40 to +60							°F/°C
Operating humidity – non condensing	< 95							%
Protection rating	NEMA3R							
FAULT CURRENT CONTRIBUTION								
Inom	25	12	40	24	36.5	40	A	
Peak	59	40	70	59	147	92	A	
1 cycle RMS ⁽⁴⁾	20	10	25	14	14	38.1	A	
3 cycle RMS ⁽⁵⁾	12	10	16.5	8	8.5	39	A	
Duration ⁽⁶⁾	15	49	18	9	5	150	ms	

(1) P/N SE9K-US0xxxxxx has Manual Rapid Shutdown for NEC 2014 compliance (NEC 2017 compliance with outdoor installation)

(2) Field replacement kit for 1 pair of inputs P/N: DCD-3PH-1TBK. Field replacement kit for 3 pairs of fuses and holders P/N: DCD-6PHK-S1.

(3) SolarEdge's 9kW and 20kW inverters operate at full power and full currents up to a temperature of 122°F / 50°C. The inverters may be used above this temperature with reduced ratings. For more information, refer to <http://www.solaredge.com/files/pdfs/se-temperature-derating-note-na.pdf>.

(4) 1 cycle RMS – the integral on one cycle (60Hz) duration

(5) 3 cycle RMS – the integral on 3-cycle duration

(6) Duration - time by which fault current reaches 0

Default Trip Limits and Times According to IEEE1547

NOTE



The inverters are equipped with adjustable utility protective function set-points, and can be aggregated above 30kW on a single Point of Common Connection. The default settings are in compliance with IEEE1547. Utility authorization is required to change these set-points.

Voltage Range (% of Base Voltage)	Maximum Clearing Time (Sec)
V < 50%	0.16
50 % < V < 88%	2.00
110% < V < 120%	1.00
V > 120 %	0.16
Frequency Range (Hz)	Maximum Clearing Time (Sec)
> 60.5	0.16
< 59.3 (Hawaii – 57)	0.16

Safety Switch

	Specifications	Unit
Maximum DC voltage	500	Vdc
Maximum DC current	32	Adc
Nominal AC voltage	208/480	Vac
Maximum AC current	32	Aac
Ambient temperature	-40 to 140 / -40 to +60	°F / °C
Weight	6.6 / 3.0	lb/kg

If you have technical queries concerning our products, please contact our support through SolarEdge service portal: www.solaredge.com/service/support

US & Canada (+1)	(0) 510 498 3200
Worldwide (+972)	(0) 073 240 3118
Fax (+1)	(0) 530 273-2769
Email	ussupport@solaredge.com