



Tigo[®]

Installation Manual

TS4-F, TS4-R-F, TS4-A-F, RSS Transmitter

IMPORTANT SAFETY INSTRUCTIONS

LETHAL VOLTAGE MAY BE PRESENT IN ANY PV INSTALLATION

SAVE THESE INSTRUCTIONS

- This manual contains important instructions for installation and maintenance of the Tigo product models TS4-F, TS4-R-F, TS4-A-F, and the RSS Transmitter.
- Risk of electric shock, do not remove cover, disassemble, or repair, no user serviceable parts inside. Refer servicing to qualified service personnel.
- Before installing or using the Tigo System, please read all instructions and warning markings on the Tigo products, appropriate sections of your inverter manual, photovoltaic (PV) module installation manual, and other available safety guides.
- Failure to adhere to these instructions may result in injury or death, damage to the system or voiding the factory warranty.
- To reduce risk of fire and shock hazard, install this device with strict adherence to National Electric Code (NEC) ANSI/NFPA 70 and/or local electrical codes. When the photovoltaic array is exposed to light, it supplies a DC voltage to the Tigo TS4 units. The TS4 units start in the "ON" state and their output voltage may be as high as the PV module open circuit voltage (VOC) when connected to the module. The installer should use the same caution when handling electrical cables from a PV module with or without the TS4 units attached.
- Installation must be performed by trained professionals only. Tigo does not assume liability for loss or damage resulting from improper handling, installation, or misuse of products.
- Remove all metallic jewelry prior to installing the Tigo TS4 units to reduce the risk of contacting live circuitry. Do not attempt to install in inclement weather.
- Do not operate the Tigo TS4 units if they have been physically damaged. Check existing cables and connectors, ensuring they are in good condition and appropriate in rating. Do not operate Tigo TS4 units with damaged or substandard wiring or connectors. Tigo TS4 units must be mounted on the high end of the PV module backsheet or racking system, and in any case above ground.
- Do not connect or disconnect under load. Turning off the Inverter and/or the Tigo products may not reduce this risk. Internal capacitors within the inverter can remain charged for several minutes after disconnecting all power sources. Verify capacitors have discharged by measuring voltage across inverter terminals prior to disconnecting wiring if service is required. Wait 30 seconds after rapid shutdown activation before disconnecting DC cables or turning off DC disconnect.
- Always assume TS4 units are in "ON" state, or may turn on when restarting.

The transmitter control power supply **MUST** be on the same AC branch circuit as the inverter to meet rapid shutdown requirements.

TABLE OF CONTENTS

TS4-F Rapid Shutdown System	4	Technical Specifications – RSS Transmitter Commercial Kit	26
TS4 Fire Safety Products	5		
System Overview: TS4-F	6	Technical Specifications – RSS Transmitter Outdoor Kit	27
System Overview: TS4-R-F	7	Testing Rapid Shutdown	28
System Overview: TS4-A-F	8	Conduit Drilling Guide	29
Installation Notes	9	Installation Complete	30
TS4-F Installation	10	Ordering Information	31
TS4-R-F Installation	11		
TS4-A-F Installation	12		
RSS Transmitter Installation – Single RSS Core	13		
RSS Transmitter Wiring – Single RSS Core	14		
RSS Transmitter Grounding – Single RSS Core	15		
RSS Transmitter Installation – Dual RSS Core	16		
RSS Transmitter Wiring – Dual RSS Core	17		
RSS Transmitter Grounding – Dual RSS Core	18		
RSS Transmitter Commercial Installation	19		
RSS Transmitter Commercial Wiring	20		
Technical Specifications – TS4-F / TS4-R-F	22		
Mechanical Specifications – TS4-F / TS4-R-F	23		
Technical Specifications – TS4-A-F	24		
Technical Specifications – RSS Transmitter	25		

TS4-F RAPID SHUTDOWN SYSTEM

Module-Level Power Electronics:

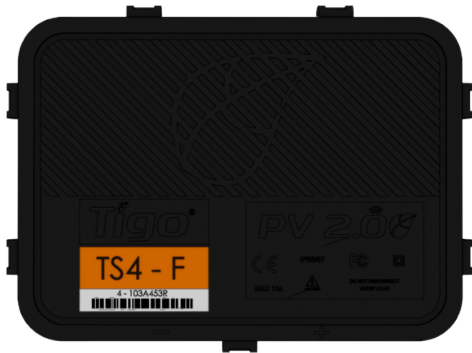

TS4-F, TS4-R-F, TS4-A-F

- NEC 2017 690.12 Rapid shutdown compliant
- Module-level deactivation
- PLC communication
- Plug & play, no configuration required

Transmitter:



RSS Transmitter

- Rapid Shutdown System Transmitter for rapid shutdown activation of TS4-F, TS4-R-F, or TS4-A-F units
- The external device that provides a keep-alive signal to the TS4-F via Power Line Communication

TS4 FIRE SAFETY PRODUCTS

Module-Integrated:



TS4-F

- Module electronics are contained in the junction box, installed at the PV module factory.
- Connected in series like regular modules
- No additional wiring connections to make

Add-on/Retrofit:

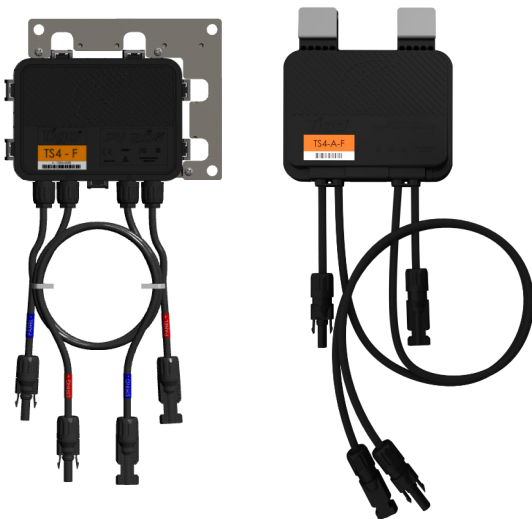

TS4-R-F, TS4-A-F

- Bracket clips to module frame without tools
- TS4-R-F or TS4-A-F outputs are connected in series to form a string
- No additional grounding required

SYSTEM OVERVIEW: TS4-F

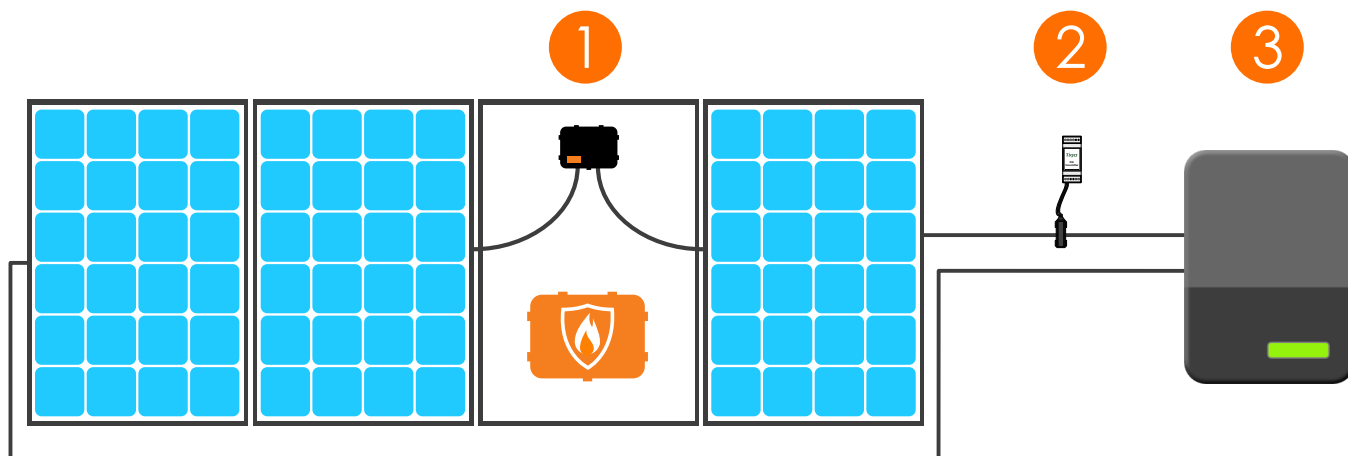

1. Modules with integrated TS4-F
2. RSS Transmitter and RSS Core
3. Inverter

The TS4-F requires a Tigo RSS Transmitter or inverter with built-in transmitter for operation.

The Tigo RSS Transmitter is installed in line with a solar PV inverter, as shown, and can be installed inside the inverter or external to it.

Method of Operation

All TS4-F units start in the OFF position and measure 0.6V at the output. When power is supplied to the RSS Transmitter, the TS4-F units turn ON and allow full PV module voltage.

The units constantly receive a “keep-alive” signal from the transmitter over PLC. When power to the transmitter is cut, this keep-alive signal ceases, sending every TS4-F into shutdown mode with output reduced to 0.6V.

SYSTEM OVERVIEW: TS4-R-F

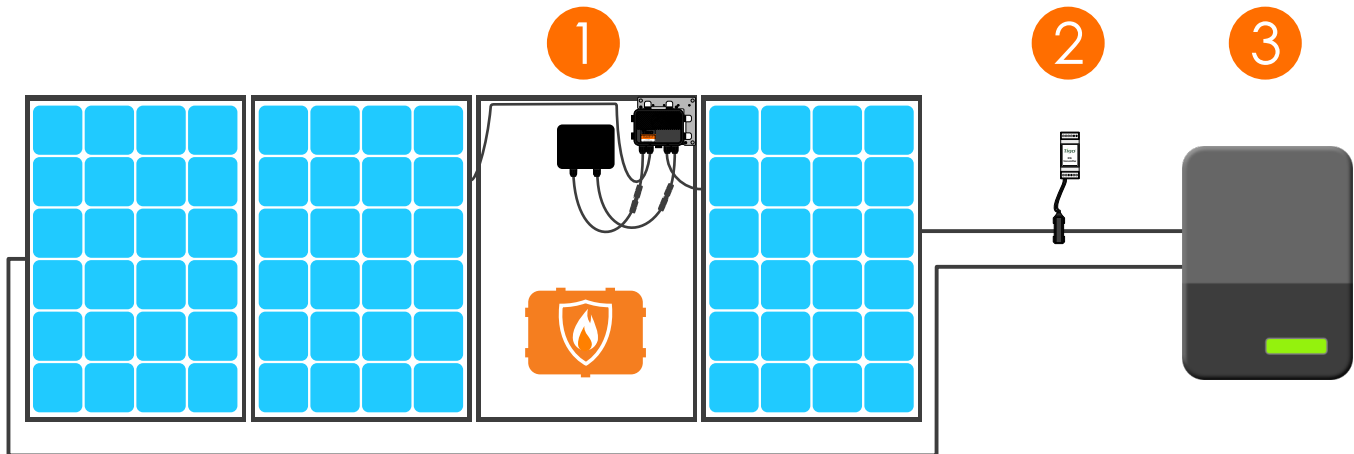

Note: connect modules to TS4-R inputs before connecting outputs

The TS4-R-F requires a Tigo RSS Transmitter or inverter with built-in transmitter for operation.

- TS4-R-F mounting is recommended on the upper right as shown, but can be placed elsewhere on the frame or bolted to the racking if needed.
- TS4-R-F cable glands must not be facing up.
- Allow clearance between PV module and mounting surface for air circulation around TS4-R-F.
- Do not drill additional mounting holes in the frame or metal bracket.

SYSTEM OVERVIEW: TS4-A-F

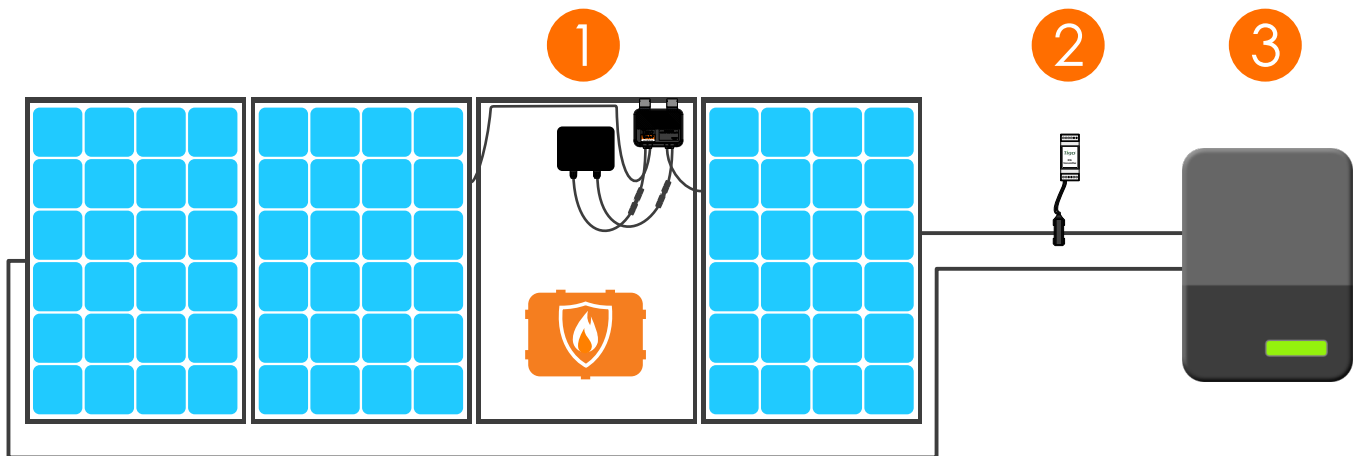

Note: connect modules to TS4-A inputs before connecting outputs

The TS4-A-F requires a Tigo RSS Transmitter or inverter with built-in transmitter for operation.

- TS4-A-F mounting is recommended on the upper right as shown, but can be placed elsewhere on the frame or bolted to the racking if needed.
- TS4-A-F cable glands must not be facing up.
- Allow clearance between PV module and mounting surface for air circulation around TS4-A-F.
- Do not drill additional mounting holes in the frame or metal bracket.

INSTALLATION NOTES

- TS4-F, TS4-R-F, and TS4-A-F are shipped in the OFF position and will measure **0.6V** at the output when the keep-alive signal is not present.
- Failing to follow the sequence of installation steps may result in TS4 damage not covered under warranty.
- Connect all TS4-R-F or TS4-A-F units to their respective modules before connecting their outputs in series.
- Install all TS4-F, TS4-R-F, or TS4-A-F units before powering on the RSS Transmitter.
- Never apply an external voltage source to a module or string equipped with TS4-F, TS4-R-F, or TS4-A-F units.
 - If parallel string connections are needed, first connect the TS4-F, TS4-R-F, or TS4-A-F to the PV modules, then connect all TS4-F, TS4-R-F, or TS4-A-F outputs in series, and finally pass one side (+ or -) of the homeruns through the PLC transmitter to turn the system ON.
- Place rapid shutdown system label no more than 1m (3ft) from initiator (AC disconnect) or service panel containing means of disconnection if not at same location.

SOLAR PV SYSTEM EQUIPPED WITH RAPID SHUTDOWN

TURN RAPID SHUTDOWN SWITCH TO THE "OFF" POSITION TO SHUTDOWN PV SYSTEM AND REDUCE SHOCK HAZARD IN ARRAY

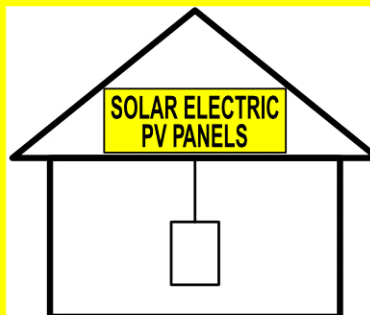

Place safety labels in proper location

TS4-F INSTALLATION

Smart modules with an integrated TS4 Junction box are installed and connected in series just like standard PV modules.

Connect modules with TS4-F in series before powering on the RSS Transmitter.

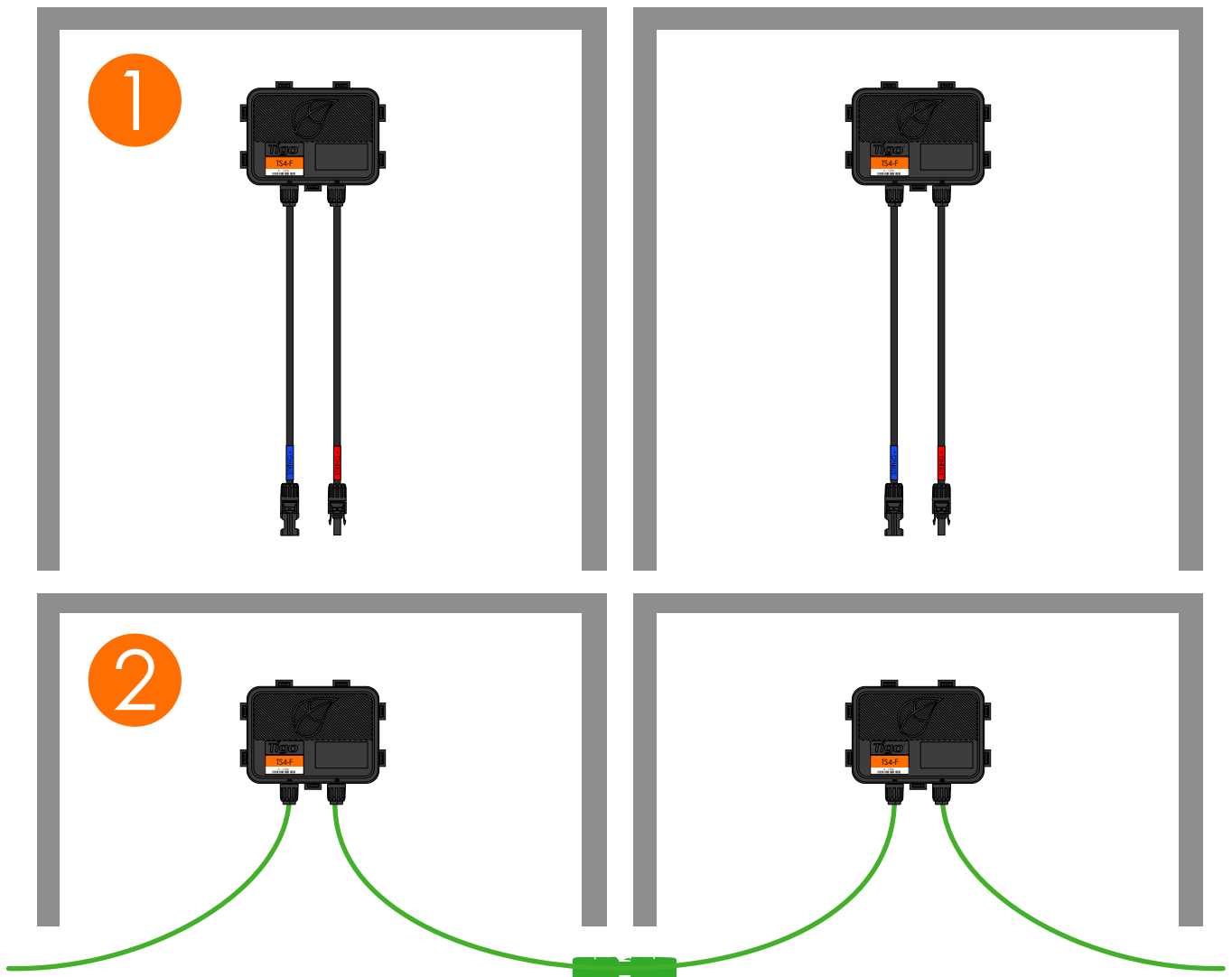

TS4-R-F INSTALLATION

Standard modules can be equipped with TS4-R-F add-on/retrofit units as shown below.

Always connect modules to TS4-R inputs before connecting outputs.

Each TS4-R-F must have a PV module connected to its input before connecting the outputs of TS4-R-F units in series.

To disconnect TS4-R-F from a module, disconnect the TS4-R-F outputs from the string before disconnecting the TS4-R-F inputs from the module junction box.

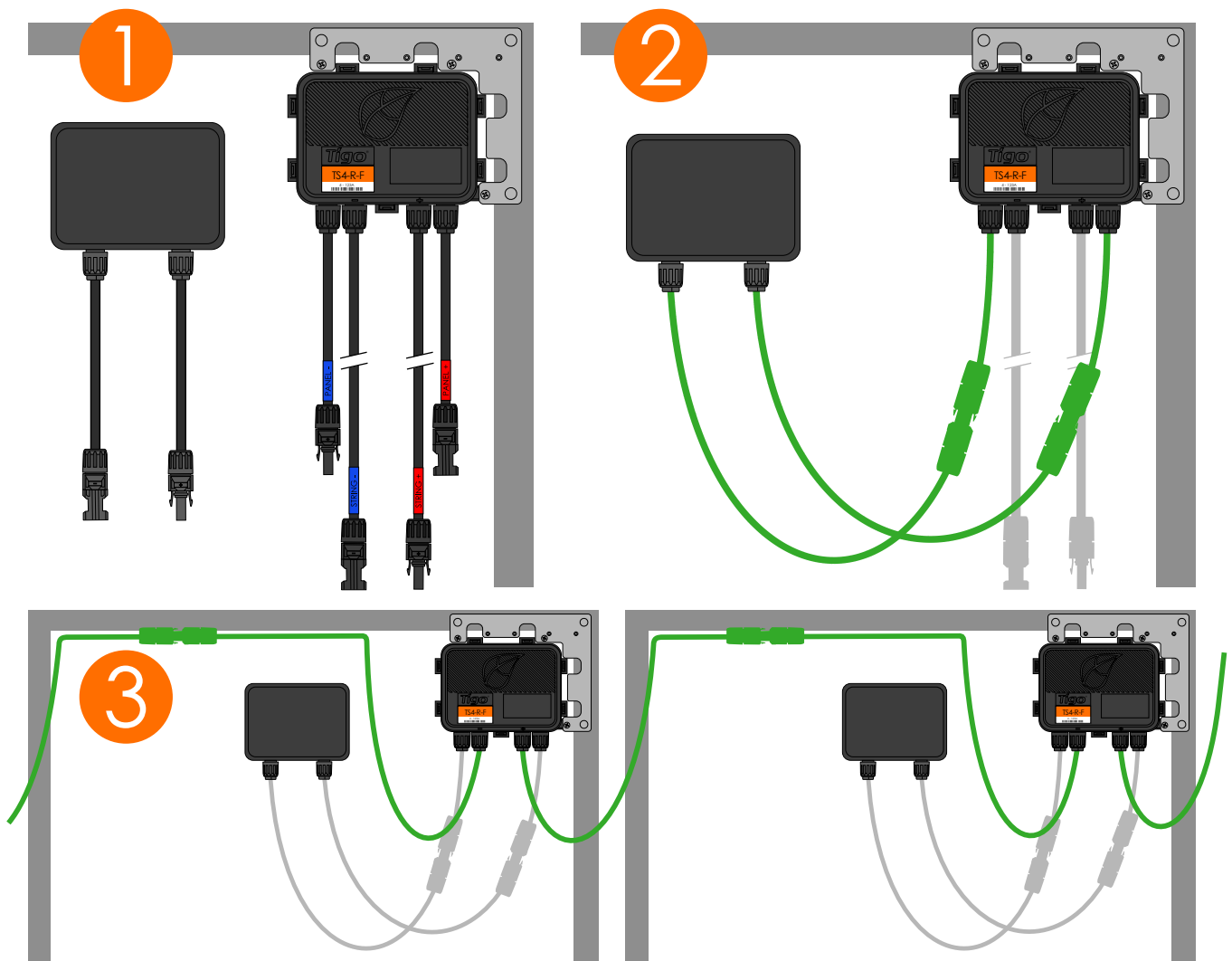

TS4-A-F INSTALLATION

Standard modules can be equipped with TS4-A-F add-on/retrofit units as shown below.

Always connect modules to TS4-A inputs before connecting outputs.

Each TS4-A-F must have a PV module connected to its input before connecting the outputs of TS4-A-F units in series.

To disconnect TS4-A-F from a module, disconnect the TS4-A-F outputs from the string before disconnecting the TS4-A-F inputs from the module junction box.

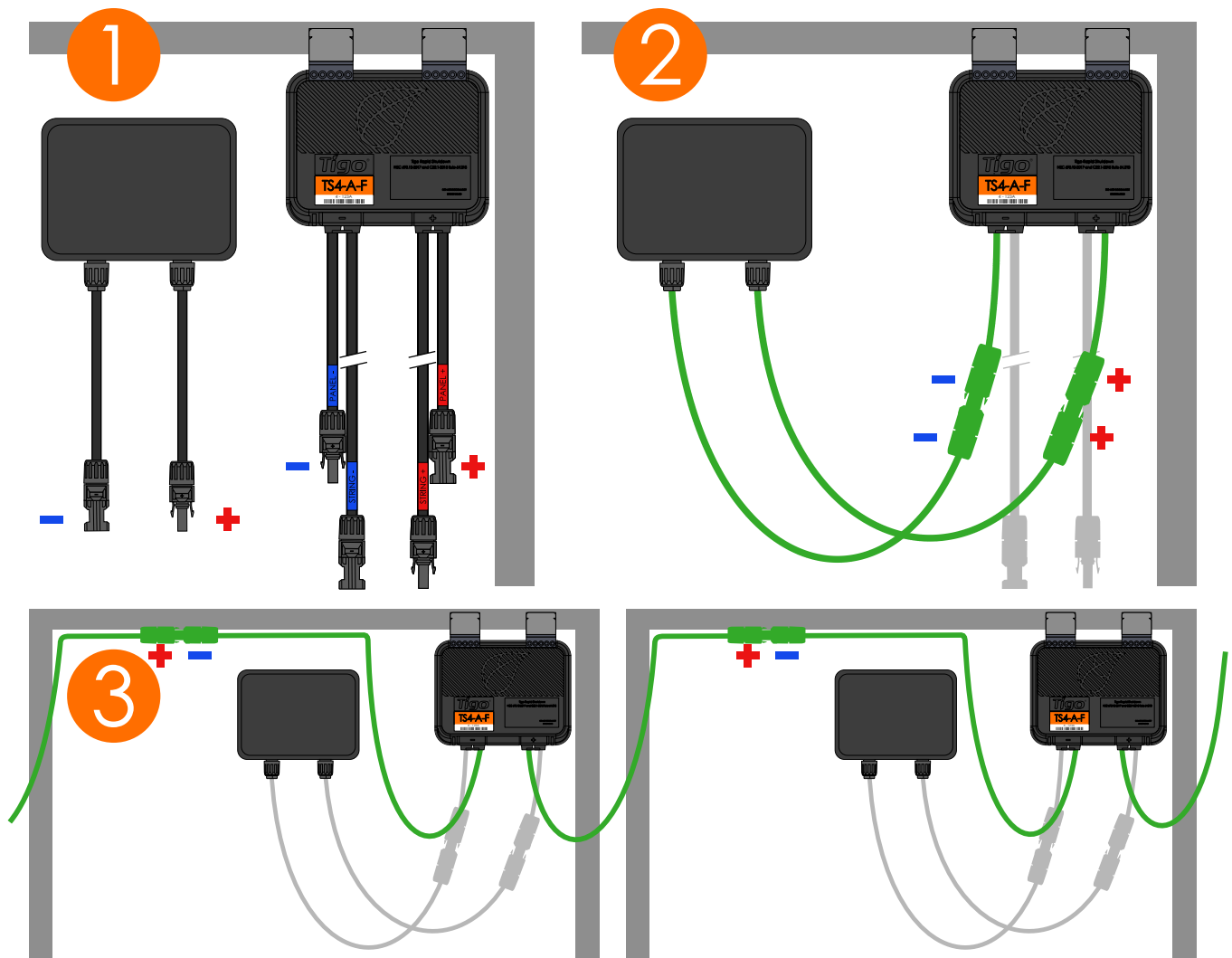

RSS TRANSMITTER INSTALLATION – SINGLE RSS CORE

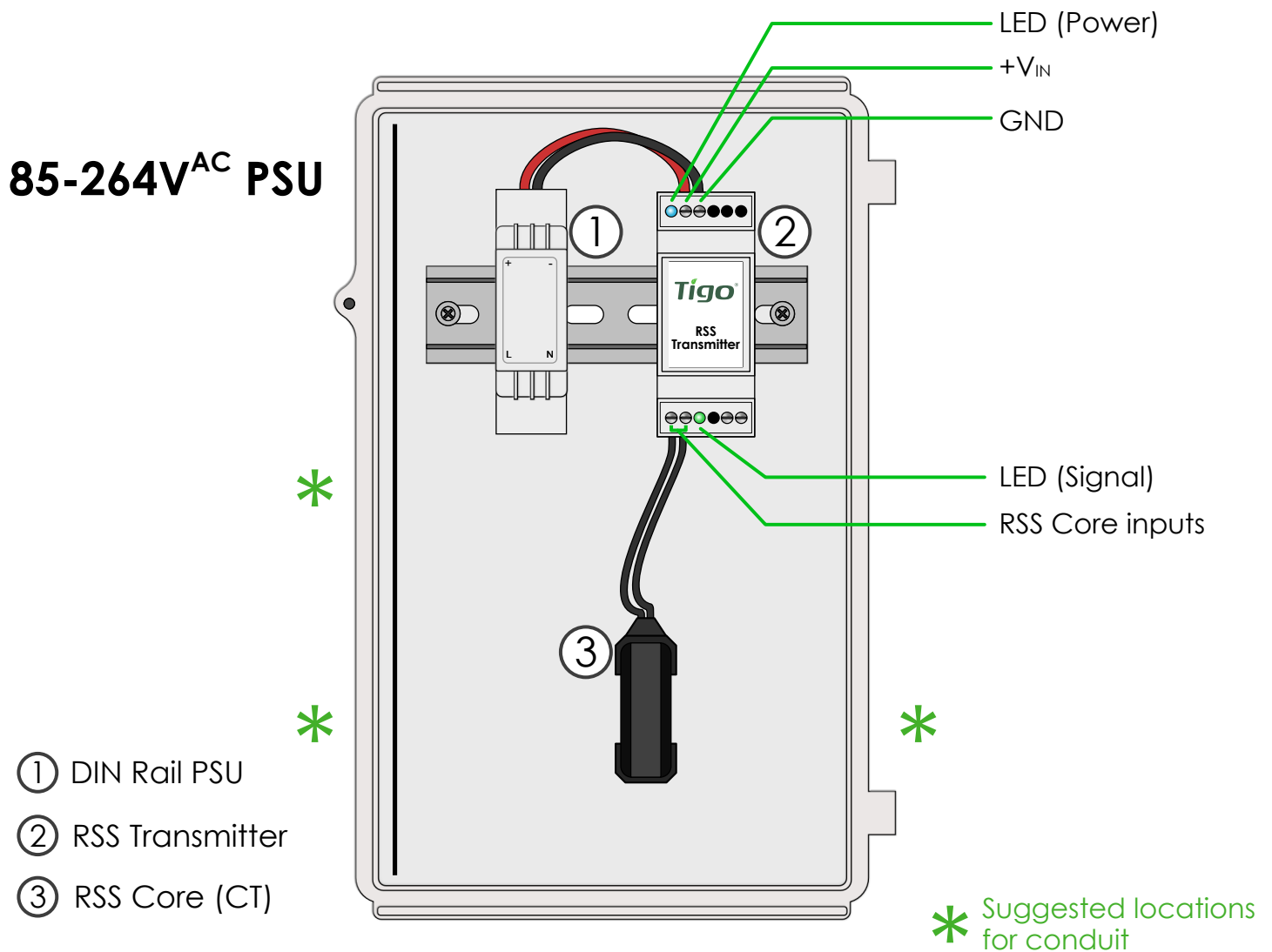

Transmitter power supply must be on same AC branch circuit as inverter to meet rapid shutdown requirements.

Note: Install TS4-F before powering on RSS Transmitter

- Drill holes in enclosure for conduit (see drilling guide for placement)
- Mount RSS Transmitter and power supply on DIN rail
- Connect DC leads from power supply ① to transmitter ②
- Connect RSS Core ③ to transmitter

Place rapid shutdown system label no more than 1 m (3ft) from RSS Transmitter or AC disconnect if not at same location.

RSS TRANSMITTER WIRING – SINGLE RSS CORE

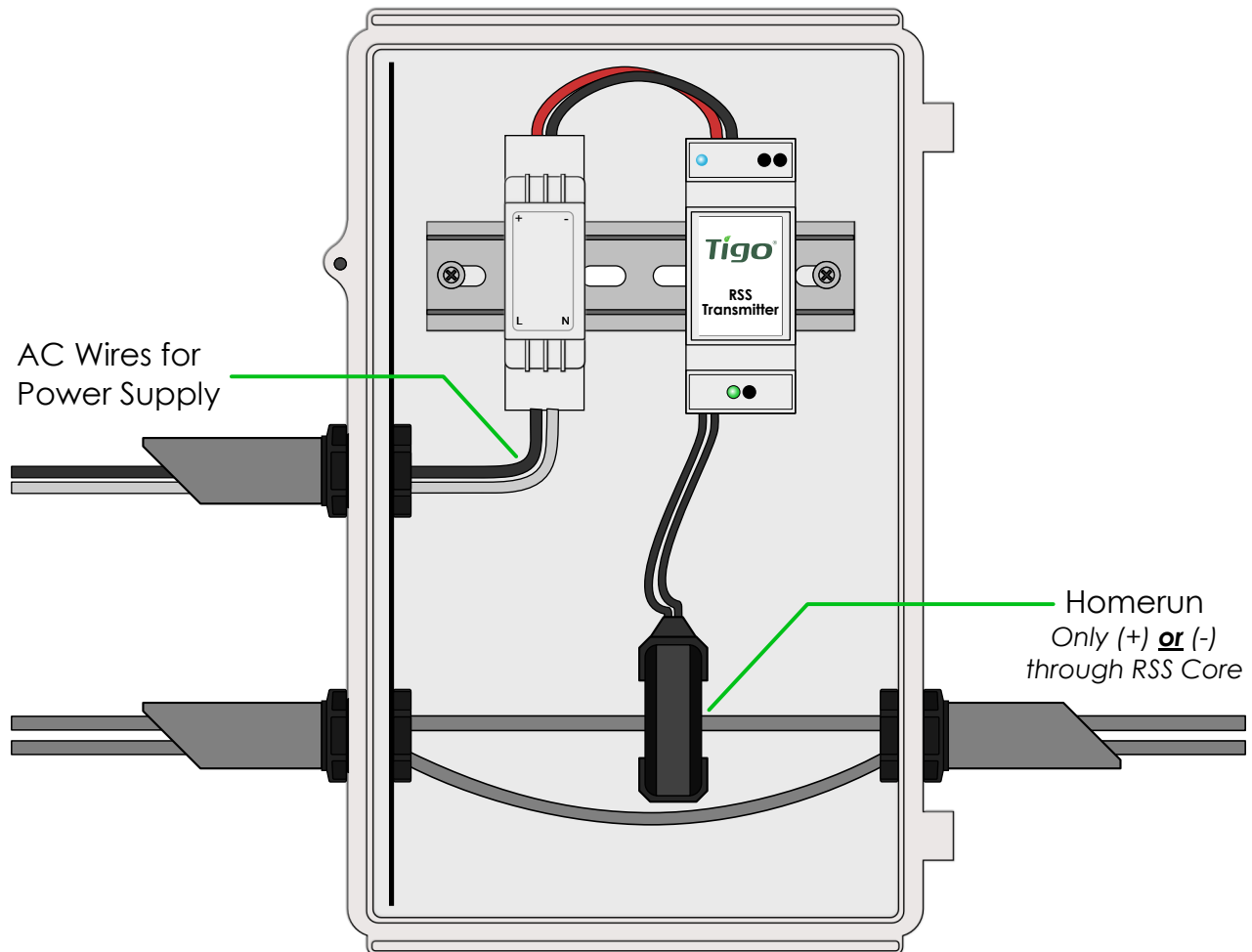

Note: Install TS4-F before powering on RSS Transmitter

- Pass either positive or negative homerun through RSS Core
- Connect wires to AC side of power supply

Max number of strings per RSS Core: **10**

Max string length: **30 modules**

Max current per RSS Core: **100A**

Max cable length from inverter (+) to inverter (-): **1000ft (300m)**

RSS TRANSMITTER GROUNDING – SINGLE RSS CORE

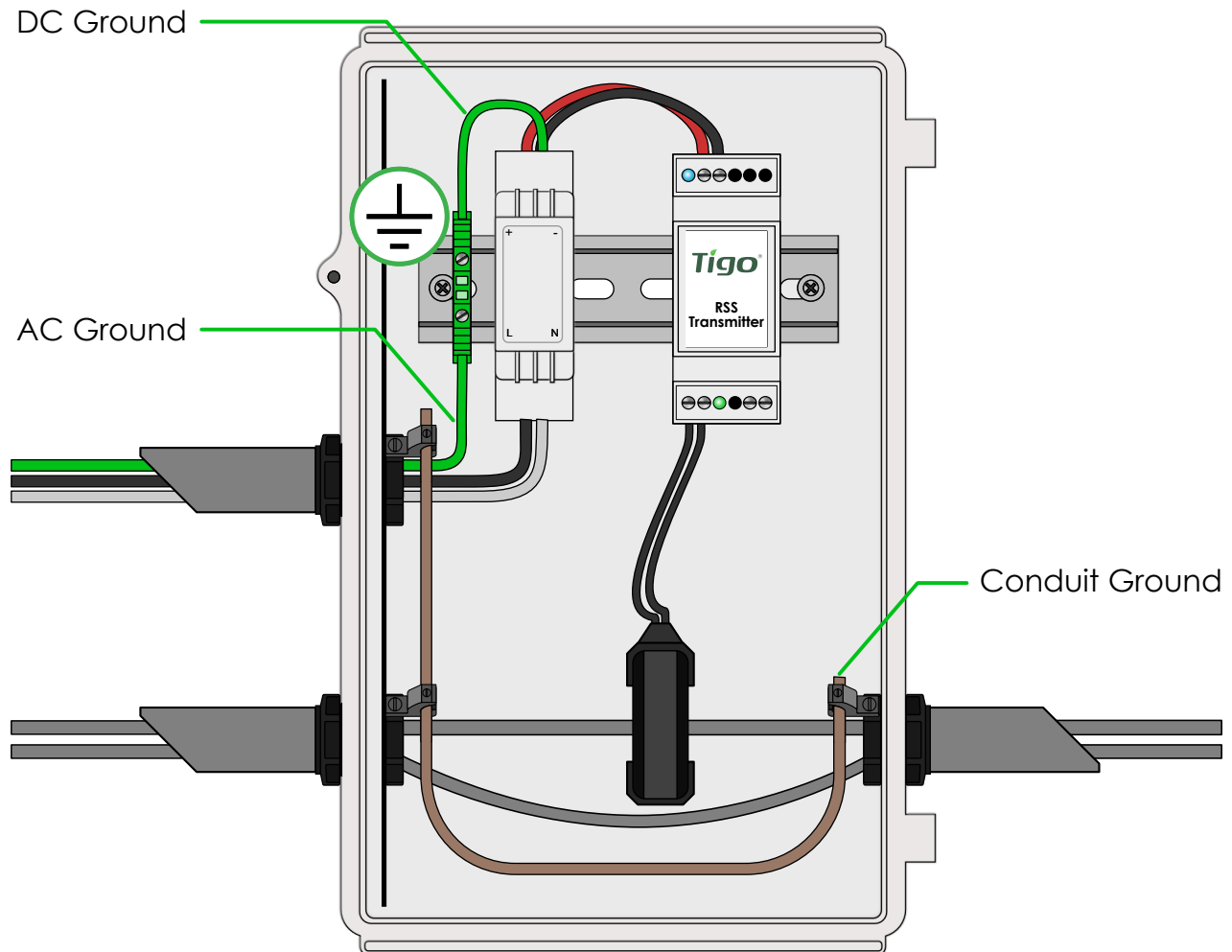

Note: Install TS4-F before powering on RSS Transmitter

- Connect AC and DC ground wires to DIN rail
- Ground all conduit connections
- Turn on AC power to Transmitter power supply to activate keep-alive signal and energize PV array

Warning: nonmetallic enclosure does not provide bonding between conduit connections. Use grounding type bushings and jumper wires.

RSS TRANSMITTER INSTALLATION – DUAL RSS CORE

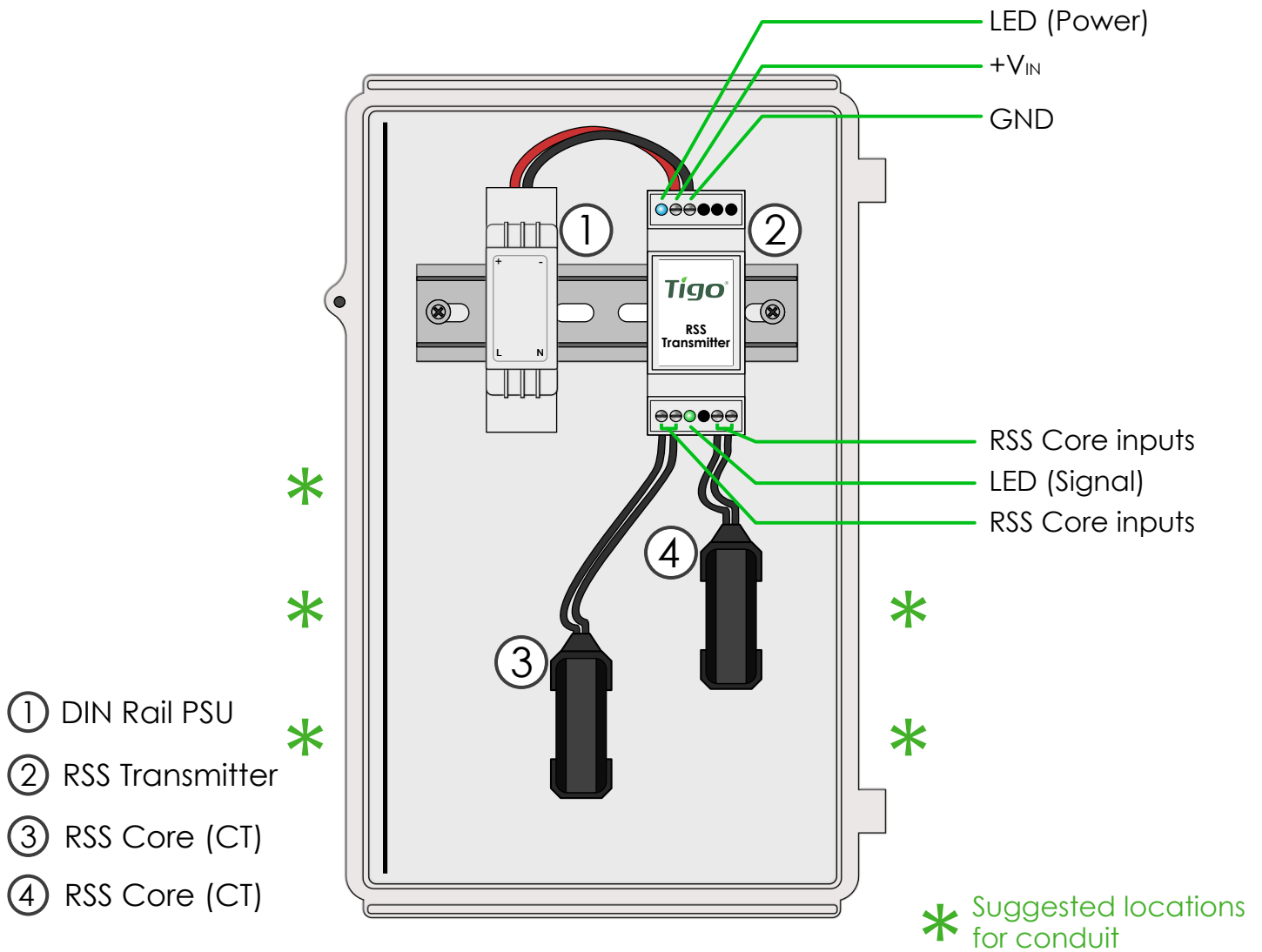

Transmitter power supply must be on same AC branch circuit as inverter to meet rapid shutdown requirements.

Note: Install TS4-F before powering on RSS Transmitter

- Drill holes in enclosure for conduit (see drilling guide for placement)
- Mount RSS Transmitter and power supply on DIN rail
- Connect DC leads from power supply ① to transmitter ②
- Connect RSS Core ③ and ④ to transmitter

Place rapid shutdown system label no more than 1 m (3ft) from RSS Transmitter or AC disconnect if not at same location.

RSS TRANSMITTER WIRING – DUAL RSS CORE

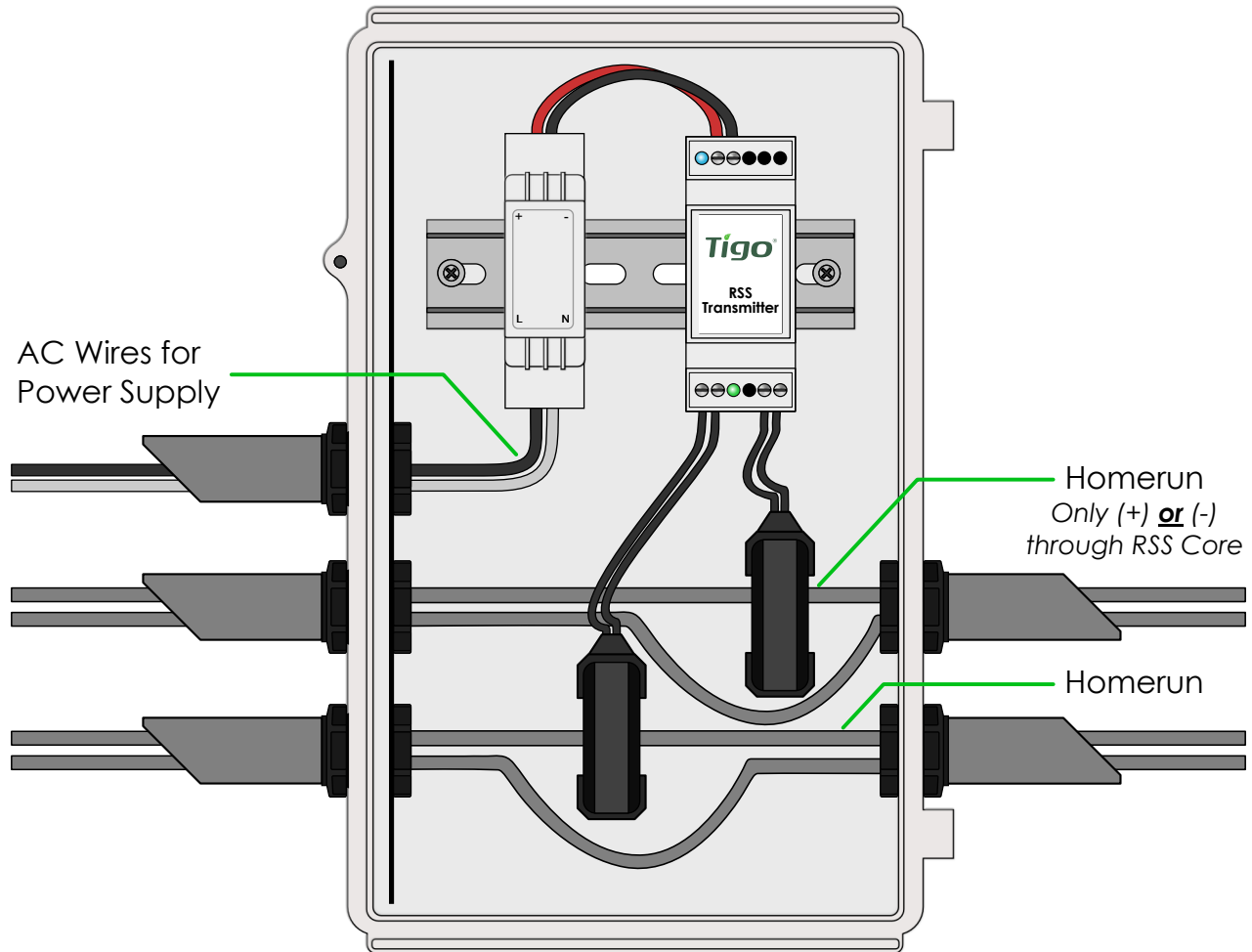

Note: Install TS4-F before powering on RSS Transmitter

- Pass either positive or negative homerun through RSS Cores
- Connect wires to AC side of power supply

Max number of strings per RSS Core: **10**

Max string length: **30 modules**

Max current per RSS Core: **100A**

Max cable length from inverter (+) to inverter (-): **1000ft (300m)**

RSS TRANSMITTER GROUNDING – DUAL RSS CORE

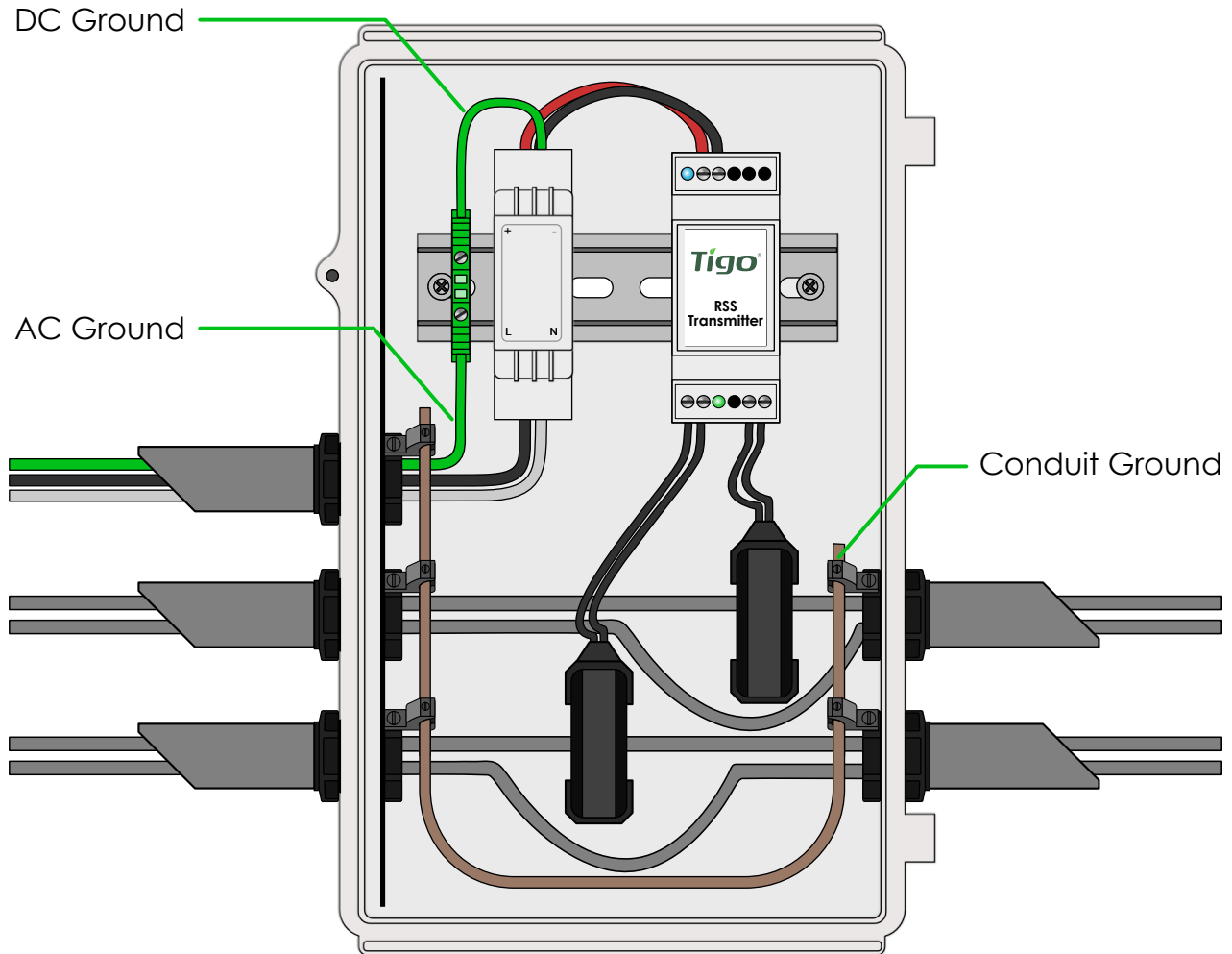

Note: Install TS4-F before powering on RSS Transmitter

- Connect AC and DC ground wires to DIN rail
- Ground all conduit connections
- Turn on AC power to Transmitter power supply to activate keep-alive signal

Warning: nonmetallic enclosure does not provide bonding between conduit connections. Use grounding type bushings and jumper wires.

RSS TRANSMITTER COMMERCIAL INSTALLATION

200-500V^{AC} Power Supply

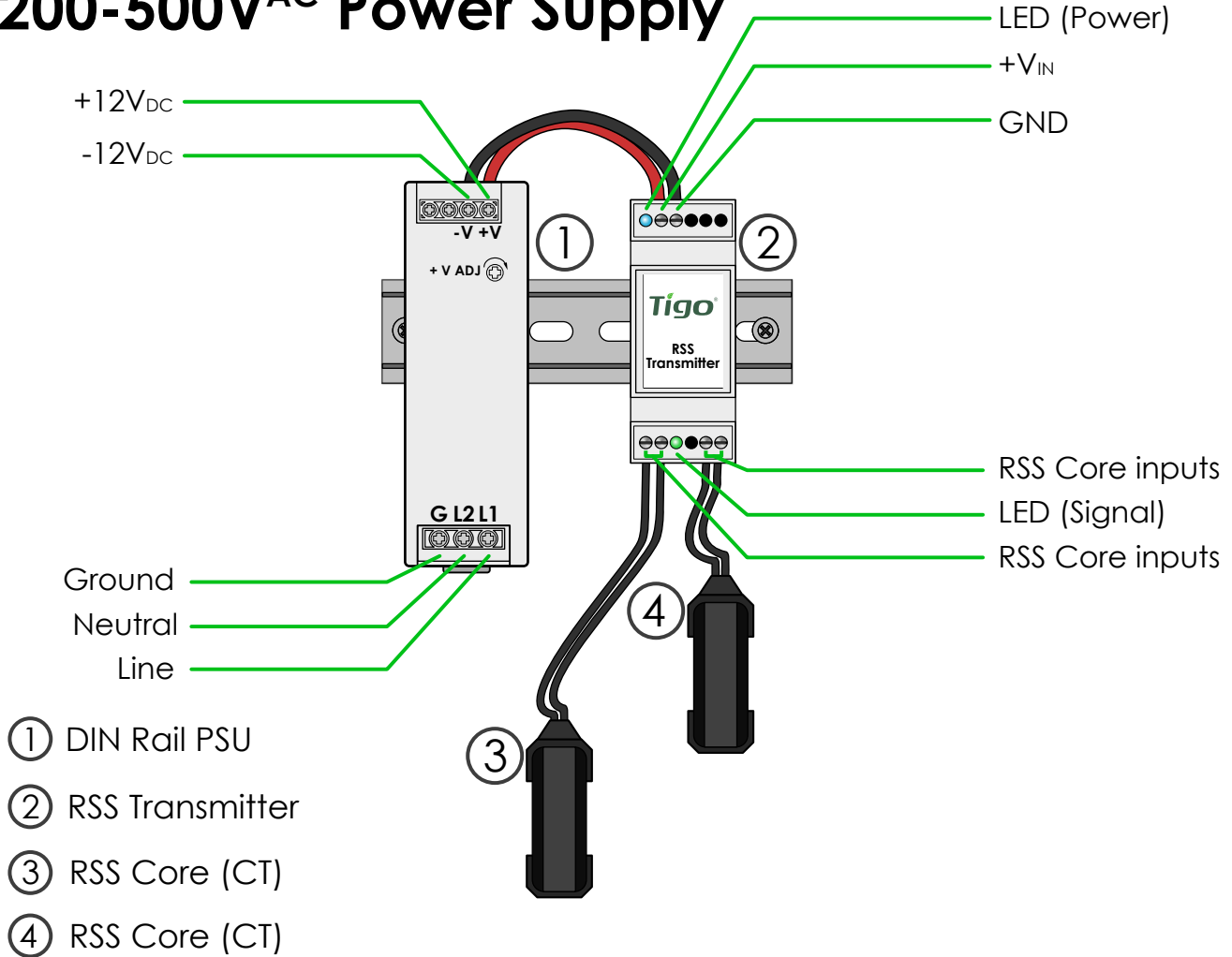

Transmitter power supply must be on same AC branch circuit as inverter to meet rapid shutdown requirements.

Note: Install TS4-F before powering on RSS Transmitter

- Mount RSS Transmitter and power supply on DIN rail
- Connect DC leads from power supply ① to transmitter ②
- Connect RSS Core ③ and ④ to transmitter

Place rapid shutdown system label no more than 1 m (3ft) from RSS Transmitter or AC disconnect if not at same location.

RSS TRANSMITTER COMMERCIAL WIRING

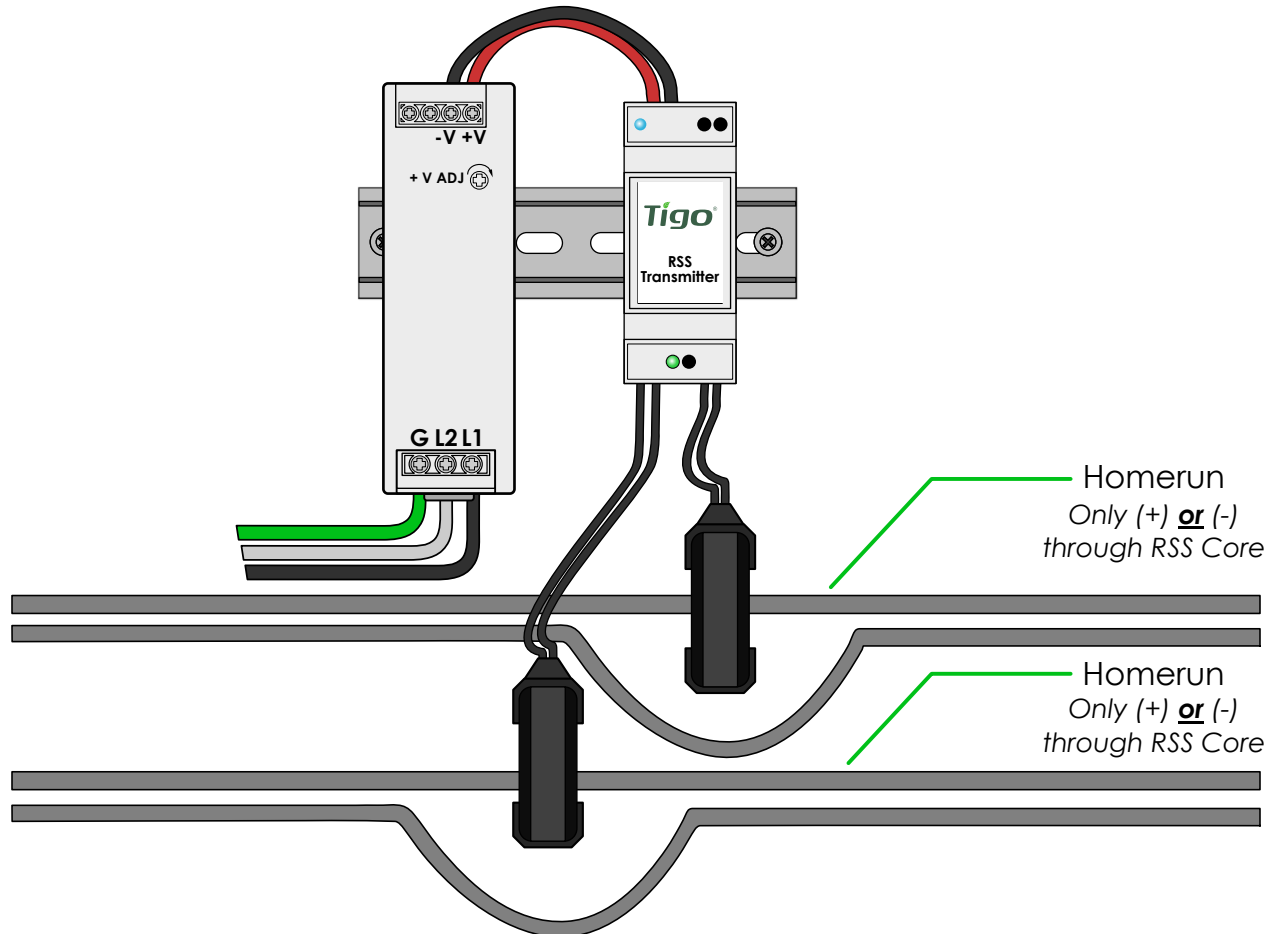

Note: Install TS4-F before powering on RSS Transmitter

- Pass either positive or negative homerun through RSS Cores
- Connect wires to AC side of power supply
- Turn on AC power to Transmitter power supply to activate keep-alive signal

Max number of strings per RSS Core: **10**

Max string length: **30 modules**

Max current per RSS Core: **150A**

Max cable length from inverter (+) to inverter (-): **1000ft (300m)**



Tigo[®]

Appendix

TS4-F, TS4-R-F, TS4-A-F, RSS Transmitter

TECHNICAL SPECIFICATIONS – TS4-F / TS4-R-F

Electrical Ratings

TS4-F / TS4-R-F Fire Safety

Input	
Rated DC Input Power	475W
Input Voltage	16 - 90V
Max Continuous Input Current (I_{MAX})	12.5A
Output	
Output Power Range	0 - 475W
Output Voltage Range	0 – V_{OC}
Communication Type	Power Line Communication (PLC)
Rapid Shutdown UL Listed (NEC 2014 & 2017 690.12)	Yes
Impedance Matching Capability	No
Output Voltage Limit	No
Maximum System Voltage	1500V
Fuse Rating	20A

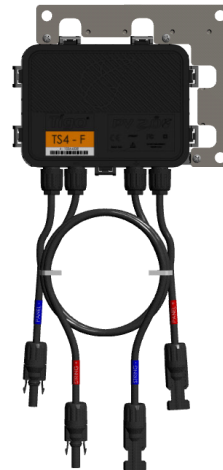

Specify system voltage when ordering (1000V / 1500V) for appropriate cables & connectors.

Rapid shutdown activation requires RSS Transmitter.

MECHANICAL SPECIFICATIONS – TS4-F / TS4-R-F

Specifications

TS4-F / TS4-R-F Fire Safety

Mechanical

Operating Temperature Range: -40°C to +70°C (-40°F to +158°F), RH < 85%

Storage Temperature Range: -40°C to +70°C (-40°F to +158°F), RH < 60%

Cooling Method: Natural Convection

Dimensions (with cover): 178.5mm x 134mm x 25.5mm

Weight (base and cover): 670g

Outdoor Rating: IP68, NEMA 3R

Cabling

Type: H1Z2Z2-K

Output Length: 1.2m standard, other lengths available

Cable Options: 1000V rated, 1500V rated

Cable Cross-Section: 6.3 ± 0.3mm

Connectors: MC4, MC4 compatible

UV Resistance: 500hr with UV light between 300-400nm @65C

Maximum System Voltage: 1500V

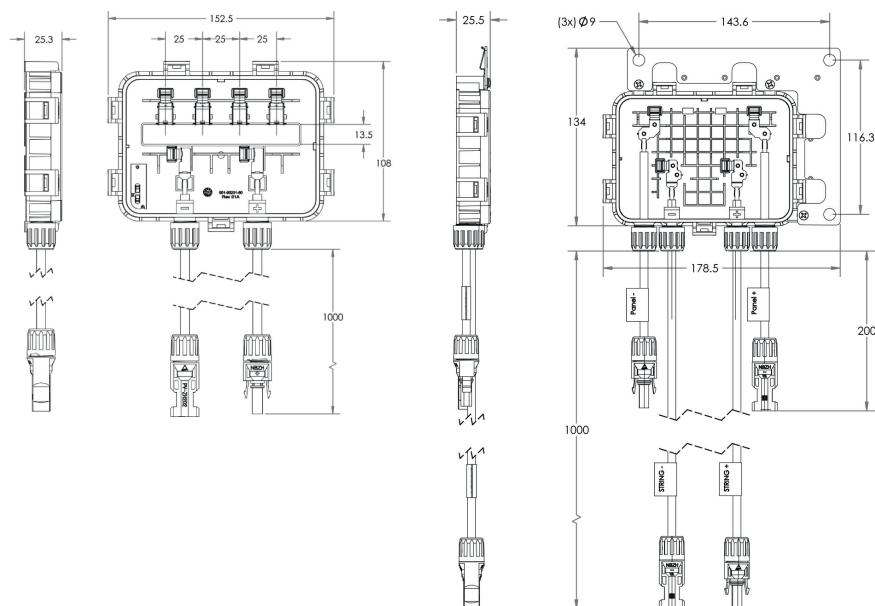

TECHNICAL SPECIFICATIONS – TS4-A-F

Specifications

TS4-A-F Fire Safety

Environmental

Operating Temperature Range	-40°C to +85°C (-40°F to +185°F)
Outdoor Rating	IP68, NEMA 3R

Mechanical

Dimensions	138.4mm x 139.7mm x 22.9mm
Weight	490g

Electrical

Input Voltage	16 - 90V
Maximum Continuous Input Current (I_{MAX})	12.5A
Maximum Power	500W
Output Cable Length	1.2m (standard), other lengths available
Connectors	MC4 compatible (standard)
Communication Type	PLC
Maximum System Voltage	1500V
Rapid Shutdown UL Listed (NEC 2014 & 2017 690.12)	Yes

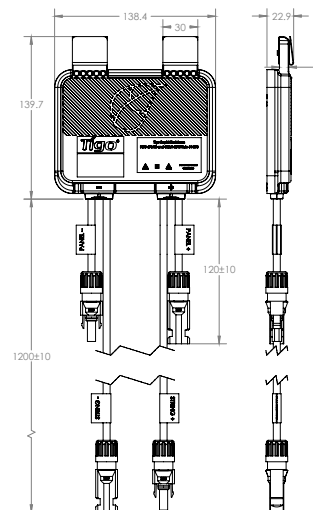

Specify system voltage when ordering (1000V / 1500V) for appropriate cables & connectors.

Rapid shutdown activation requires RSS Transmitter.

TECHNICAL SPECIFICATIONS – RSS TRANSMITTER

Electrical Ratings

RSS Transmitter

Input

Input Voltage	12V _{DC}
Input Current	1A
Average Supply Power	0.85W
Dimensions(Transmitter only)	90.2mm x 36.3mm x 57.7mm

RSS Core

Maximum Current	150A per Core (Single Core: 150A, Dual Core: 300A)
Maximum MPPT String Voltage	1500V _{DC}
Internal Opening for Wires	~25mm
Outside Dimensions	59mm
Maximum Number of Strings per Core	10
Maximum String Length	30 modules

Environmental

Temperature	-40°C to 85°C
-------------	---------------

Recommended max. torque 0.79 N/m for wiring

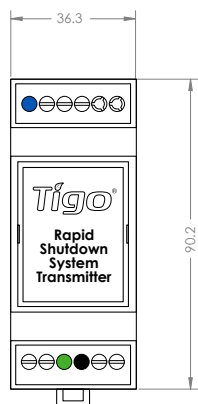

RSS Transmitter

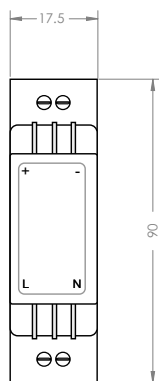

Optional Power Supply

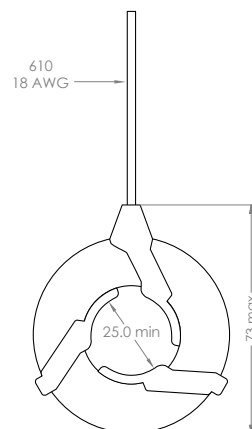

RSS Core

All dimensions in mm.

TECHNICAL SPECIFICATIONS – RSS TRANSMITTER COMMERCIAL KIT

Electrical Ratings	RSS Transmitter
Input	
Input Voltage	12V _{DC}
Input Current	1A
Average Supply Power	0.85W
Included Power Supply Rating	480/277V _{AC} input, 12V _{DC} output
Dimensions(Transmitter only)	90.2mm x 36.3mm x 57.7mm
RSS Core	
Maximum Current	150A per Core (includes 2 Cores for 300A)
Maximum MPPT String Voltage	1500V _{DC}
Internal Opening for Wires	~25mm
Outside Dimensions	59mm
Maximum Number of Strings per Core	10
Maximum String Length	30 modules
Environmental	
Temperature	-40°C to 85°C

Recommended max. torque 0.79 N/m for wiring

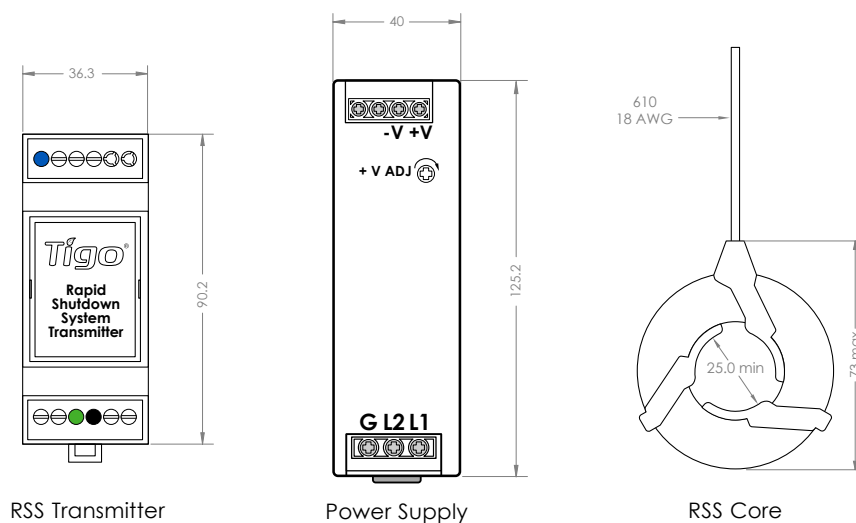

All dimensions in mm.

TECHNICAL SPECIFICATIONS – RSS TRANSMITTER OUTDOOR KIT

Electrical Ratings

RSS Transmitter

Input

Input Voltage	12V _{DC}
Input Current	1A
Average Supply Power	0.85W
Dimensions(Transmitter only)	90.2mm x 36.3mm x 57.7mm

RSS Core

Maximum Current	100A per Core (Single Core: 100A, Dual Core: 200A)
Maximum MPPT String Voltage	1500V _{DC}
Internal Opening for Wires	~25mm
Outside Dimensions	59mm
Maximum Number of Strings per Core	10
Maximum String Length	30 modules

Environmental

Temperature	-40°C to 85°C
-------------	---------------

Recommended max. torque 0.79 N/m for wiring

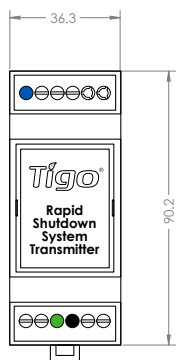

RSS Transmitter

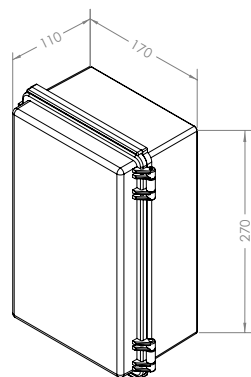

Outdoor Enclosure

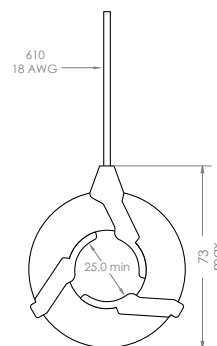

RSS Core

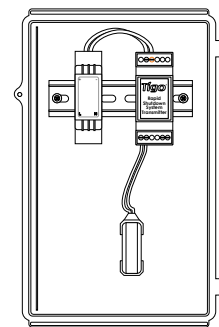

Installation Example

All dimensions in mm.

TESTING RAPID SHUTDOWN

TS4-F (or TS4-R-F / TS4-A-F) and an RSS Transmitter are a solution to meet NEC 2014 & 2017 690.12 Rapid Shutdown requirements.

TS4-F, TS4-R-F, and TS4-A-F units automatically enter rapid shutdown mode when the RSS Transmitter is switched off and resume energy production when power is restored to the RSS Transmitter.

Wait 30 seconds after rapid shutdown activation before disconnecting DC cables or turning off DC disconnect.

Test your rapid shutdown system by switching off the AC power to the RSS Transmitter or inverter with built-in transmitter.

TS4-F, TS4-R-F, and TS4-A-F units will reduce their output to 0.6V when the Transmitter is powered off.

SOLAR PV SYSTEM EQUIPPED WITH RAPID SHUTDOWN

TURN RAPID SHUTDOWN SWITCH TO THE "OFF" POSITION TO SHUTDOWN PV SYSTEM AND REDUCE SHOCK HAZARD IN ARRAY

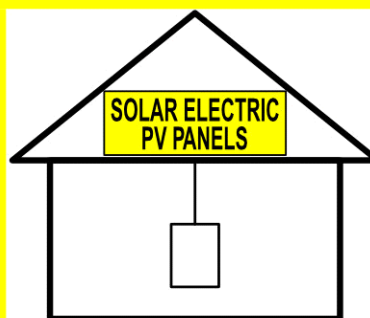

Place safety labels in proper location

The RSS Transmitter control power supply MUST be on the same AC branch circuit as the inverter to meet rapid shutdown requirements.

CONDUIT DRILLING GUIDE

Enclosure Drilling Guide for .75" Conduit

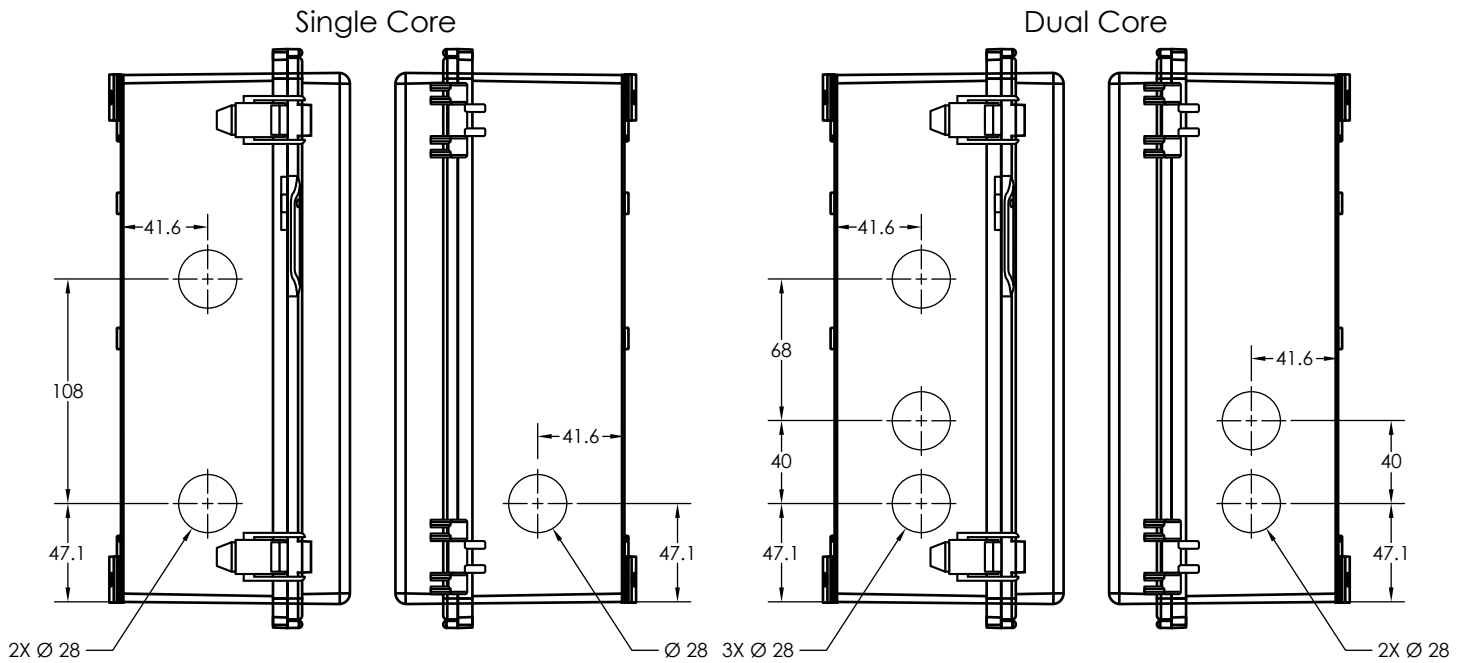

Enclosure Drilling Guide for 1" Conduit

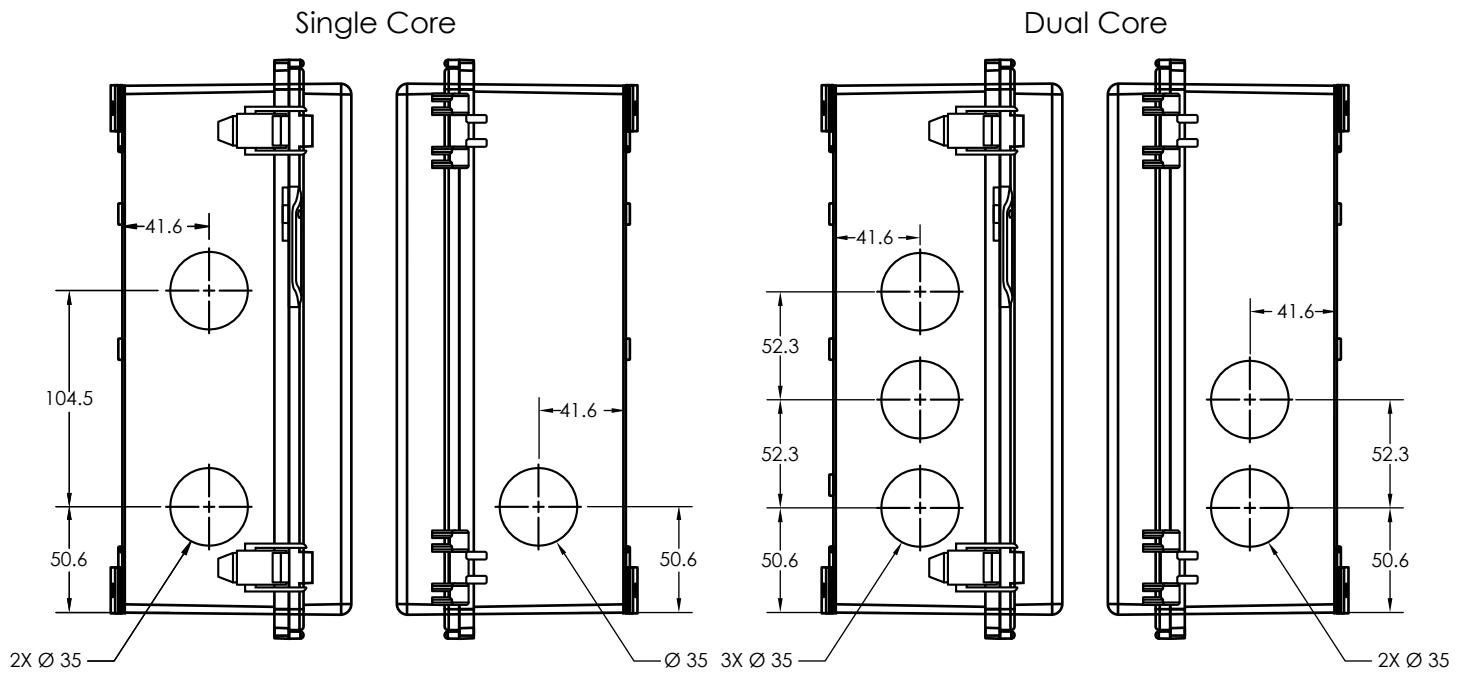

*all dimensions in mm

INSTALLATION COMPLETE

Problems?

[TS4-F Troubleshooting Guide](#)

For more details on designing and installing solutions powered by Tigo, please visit:

[Tigo Academy](#)
[Resource Center](#)

Or contact us at:

training@tigoenergy.com



ORDERING INFORMATION

Part # Description

Transmitter

490-00000-10	Single Core (150A) RSS DIN Rail Transmitter (no power supply)
490-00000-20	Dual Core (300A) RSS DIN Rail Transmitter (no power supply)
493-00000-20	Commercial Dual Core RSS DIN Rail Transmitter, 480/277V _{AC} Power Supply
492-00000-10	Single Core RSS DIN Rail Transmitter Kit, 120/240V _{AC} Power Supply, Outdoor Enclosure
492-00000-20	Dual Core RSS DIN Rail Transmitter Kit, 120/240V _{AC} Power Supply, Outdoor Enclosure
490-00100-10	Single RSS Core, RSS Transmitter PCBA
490-00100-20	Dual RSS Core, RSS Transmitter PCBA
983-01512-00	DIN Rail Power Supply, 12V _{DC} , 1.25A

TS4-A-F

Standard

458-00257-12 1000V UL / TÜV, 1.2m cable, MC4 compatible

Options

458-00252-32 1000V UL / TÜV, 1.2m cable, MC4

458-00257-00 1000V UL / TÜV, 1m cable, MC4 compatible

458-00252-12 1000V UL / TÜV, 1m cable, MC4

458-00261-32 1500V UL / TÜV, 1.2m cable, EVO2

458-00261-12 1500V UL / TÜV, 1m cable, EVO2

For sales info:

sales@tigoenergy.com or 1.408.402.0802

For technical information:

<http://support.tigoenergy.com>

For product info:

Visit www.tigoenergy.com/products

For technical info:

<http://support.tigoenergy.com>

For additional info and product selection assistance, use Tigo's online design tool at www.tigoenergy.com/design

