

Feature:

- Bi-directional All-in-One Design
- Compact Size
Highly Integration = Installation hassle-free
- Certified by UL
UL458 & Supplement SA / CSA C22.2 No. 107.1-01
UL1741 / CSA C22.2 No. 107.1-01 / KKK-A-1822F (For Ambulance)
- 5-in-1 Operating Modes
1. Inverter mode 2. Charger mode 3. Power Sharing 4. Power Generation
5. Power Support



		SC-2000-112	SC-2000-124	SC-2000-212	SC-2000-224
Inverter Mode					
Input	Nominal Voltage	12 VDC	24 VDC	212 VDC	24 VDC
	Input Voltage Range ($\pm 0.5V$)	10.5 ~ 16.5 VDC	21.0 ~ 33.0 VDC	10.5 ~ 16.5 VDC	21.0 ~ 33.0 VDC
	Input Over-Voltage Protection ($\pm 0.5V$)	16.5 VDC	33.0 VDC	16.5 VDC	33.0 VDC
	Input Over-Voltage Warning ($\pm 0.5V$)	15.5 VDC	31.0 VDC	15.5 VDC	31.0 VDC
	Input Under-Voltage Protection ($\pm 0.5V$)	10.5 VDC	21.0 VDC	10.5 VDC	21.0 VDC
	Input Under-Voltage Warning ($\pm 0.5V$)	11.0 VDC	22.0 VDC	11.0 VDC	22.0 VDC
	Input Current (Max)	260 A	130 A	260 A	130 A
	No Load Current	< 4.0 A @12.5V	< 2.0 A @25V	< 4.0 A @12.5V	< 2.0 A @25V
	Stand-By Current	< 0.4 A	< 0.2 A	< 0.4 A	< 0.2 A
Output	Continuous Output Power	2000 VA \pm 3%			
	Surge Power	Load 101%~115% (1 Min) / 4000 VA (2 Sec)			
	Frequency	50/60 Hz \pm 0.3 Hz (User-selectable)			
	Output Voltage	100 / 110 / 115 / 120VAC \pm 3%		200 / 220 / 230 / 240VAC \pm 3%	
	Max. Efficiency (Full Load)	89%	90%	89%	90%
	Output Waveform	Pure Sine Wave (THD < 5% @ 12.5V/25V/115VAC, linear load) / (THD < 3% @ 12.5V/25V/230VAC, linear load)			
	INV. AC Output*	20A MAX		10A MAX	
	AC Output*	30A MAX		26A MAX	
	Protection	Input Protection	Over / Under Voltage, Reverse Polarity (Internal Fuse)		
AC Output Protection		Short-Circuit, Overload			
AC Input Protection		30 Amp Circuit Breaker		16 Amp Circuit Breaker	
Temperature protection		Shutdown			
Battery Temperature protection		By a RJ-11 connector to battery Temperature sensor			
Charger Mode					
AC input	Nominal Voltage / Frequency	110 VAC, 50 / 60Hz (User-selectable)		230 VAC, 50 / 60Hz (User-selectable)	
	Input Voltage Range	90 ~ 132 VAC		180 ~ 264 VAC	
	Input Frequency Range	50Hz:47 ~ 53 Hz / 60Hz:57 ~ 63 Hz			
	Nominal Current	16.5A (@110VAC)		7.9A (@230VAC)	
	Efficiency (Max.)	>88%			
	AC Input*	30 A MAX		16 A MAX	
	Power Factor Correction (PFC)	>0.95 (Max.)			
Auxiliary DC Output	Output Voltage	Battery Voltage			
	Output Current	20A Max			
DC Output	Charging Current Range	25 / 50 / 75 / 100A	12.5 / 25 / 37.5 / 50A	25 / 50 / 75 / 100A	12.5 / 25 / 37.5 / 50A
	Max. Output Voltage	14.4 VDC @ GEL TYPE	28.8 VDC @ GEL TYPE	14.4 VDC @ GEL TYPE	28.8 VDC @ GEL TYPE
	Battery Temperature Compensation	-25 mV per $^{\circ}C$	-50 mV per $^{\circ}C$	-25 mV per $^{\circ}C$	-50 mV per $^{\circ}C$
	Battery Control (3-stage Battery Chargers)	Bulk / Absorption / Float			
Signal and Control	Remote Control Panel (Optional)	CR-20C / CR-16B / CR-8			
	Remote Control Terminal	Controls the inverter ON / OFF operation			
	Dry Contact Terminal	By a relay			
	Relay Specification	30 Amp / 120 VAC @ 110V system		16 Amp / 250 VAC @ 230V system	
Environment					
Operating Temperature Range	Full Load	-20 $^{\circ}C$ ~ 40 $^{\circ}C$			
	Power de-rating	60 W / $^{\circ}C$, 41~60 $^{\circ}C$			
	Storage	-30 $^{\circ}C$ ~70 $^{\circ}C$			
Operating Humidity Range	Max 93%, Non-condensing				
Cooling	Temperature & Load Controlled Cooling Fan				

	SC-2000-112	SC-2000-124	SC-2000-212	SC-2000-224
Safety and EMS	UL458 & Supplement SA / UL1741		EN 62368-1	
Safety Standards	---		Certified CISPR 25; ISO7637-2	
E-mark	---		Certified FCC Class A*	
EMC Standards	Certified FCC Class A*		EN55032 Class A*, EN55024 Class A*	
			EN61000-3-2, 3-3, EN61000-4-2, 3, 4, 5, 6, 8, 11	
Other				
Dimension (W x H x D)	251 x 116 x 453mm			
Net Weight	6 Kg			

*Max Inverter output define inverter 100% load output at Vac =100V / 200V

*Max AC output define AC input current + Inverter output current, cannot over AC input limit.

*Max AC input current Limit by the Breaker

*SC series is a class A product. In a domestic environment this product may cause radio interference in which case the user may be required to take adequate measures.

■ The Battery Charger

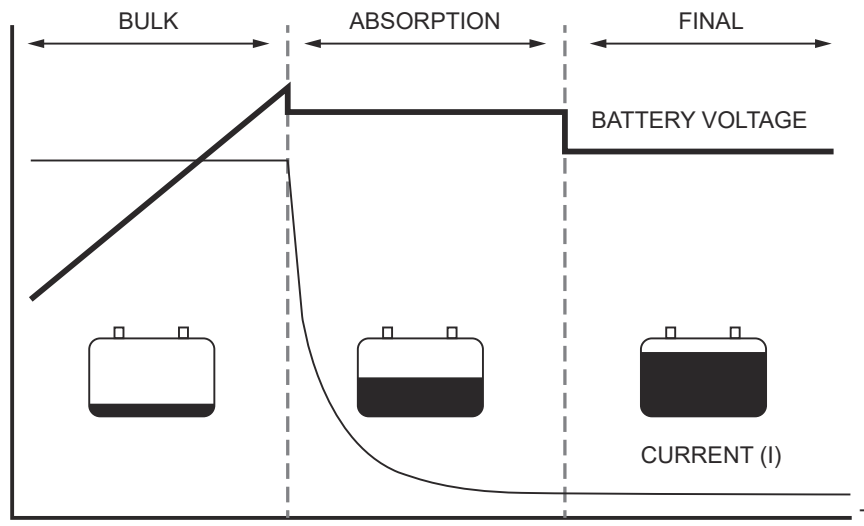

Three step charge system

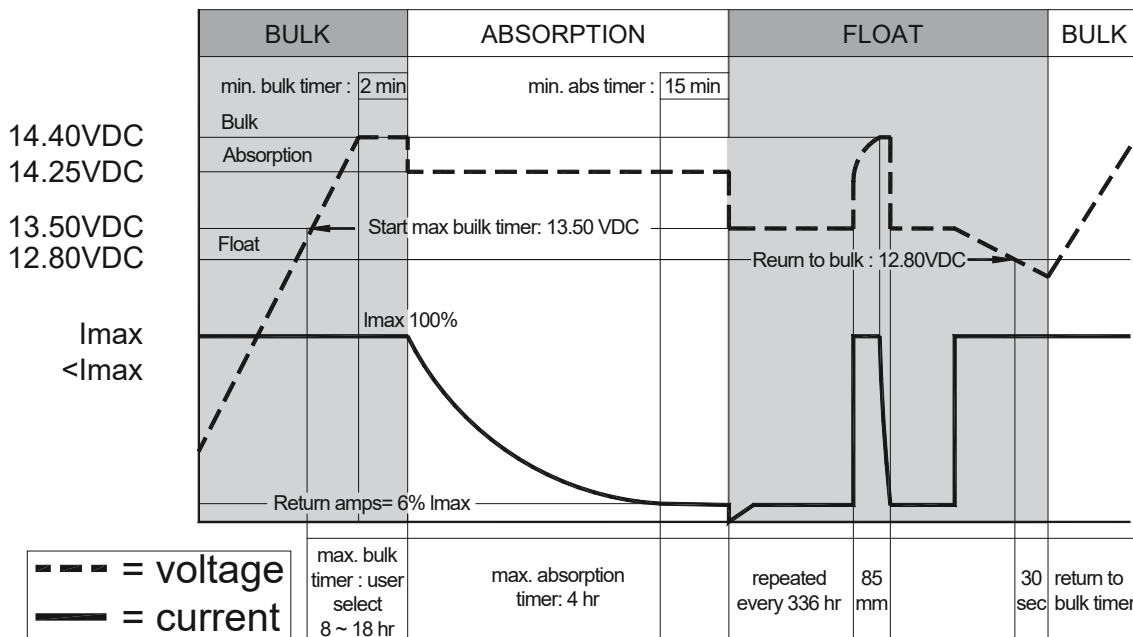

Charge characteristic of three-step plus charging method

■ Front panel

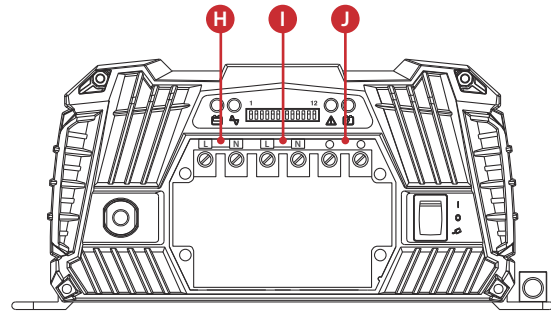
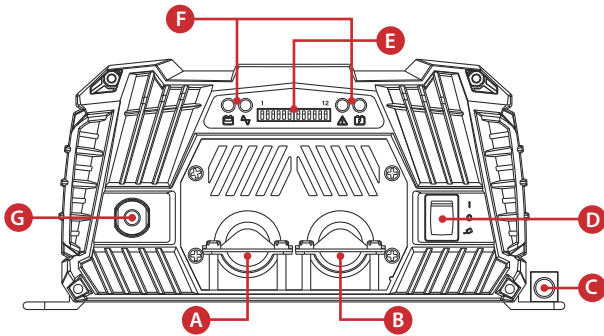

- (A) AC Output
- (B) AC Input
- (C) Chassis ground
- (D) Main switch
- (E) DIP switch
- (F) Function LED
- (G) AC input breaker
- (H) AC Output terminal (L/N)
- (I) AC Input terminal (L/N)
- (J) AC In/Output ground terminal

■ Function LED

BAT : Display input voltage

LED Status	DC12V	DC24V
Red	< 11.0V	< 22.0V
Orange	11.0 ~ 11.5V	22.0 ~ 23.0V
Green	11.5 ~ 15.0V	23.0 ~ 30.0V
Orange	15.0 ~ 15.5V	30.0 ~ 31.0V
Red	>15.5V	>31.0V

Load: Display AC loads (PF=1)

LED Status	SC-1200 / SC-2000
Red	> 115%
Orange	100 ~ 115%
Green	0 ~ 100 %
Dark	Charger Mode

Charger : Display Charger Stage

LED Status	SC-1200 / SC-2000
Orange Blink	Bulk
Orange	Absorption
Green	Float
Red	Charger Error
Green Fast Blink	Active
Green Slow Blink	Equalization
Dark	Inverter Mode

Charger : Display Charger Stage

LED Status	Status
Green	Normal
Green Slow Blink	OTP
Green Fast Blink	UTP
Orange	PLL/Frequency Fail
Orange Slow Blink	AC in UVP/OVP
Orange Fast Blink	AC IN OCP
Red	OLP / SCP
Red Slow Blink	Battery UVP
Red Fast Blink	Battery OVP

*GEL Battery TYPE No Equalization function

**"Equalization function" can only open with communication

■ The Battery Charger

Temperature Compensation using BTS

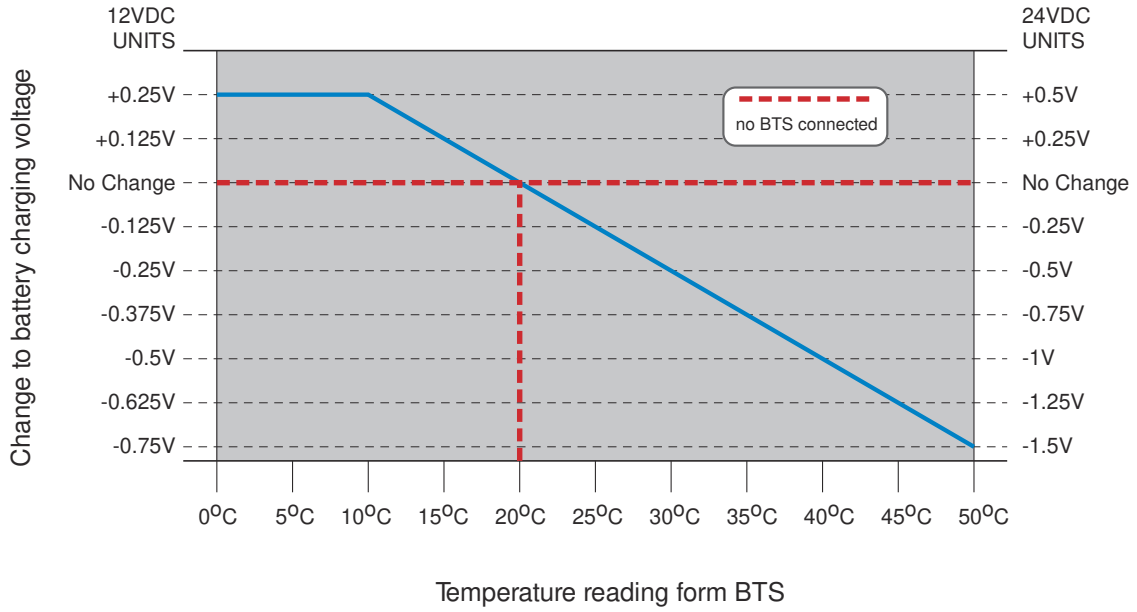

■ Mechanical Drawings

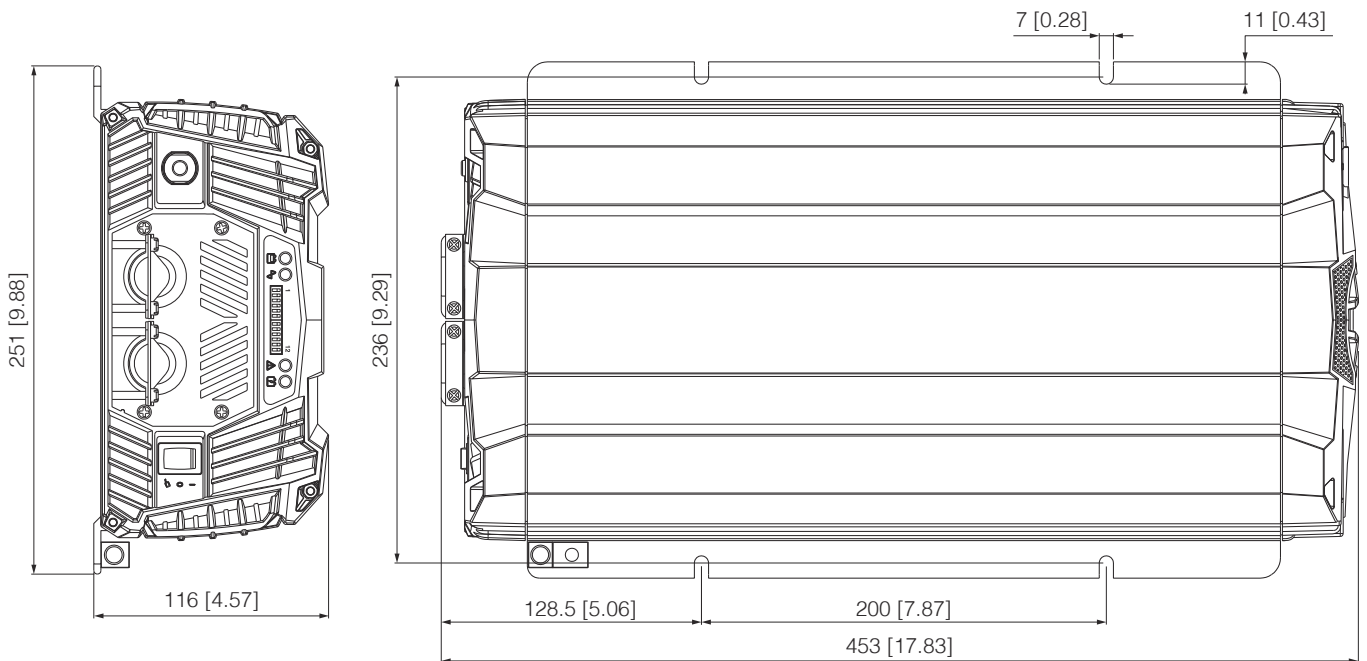

■ Dip switch Function

Dip Switch	Function
S1	Output Voltage Select
S2	
S3	Frequency Select
S4	AC Input Current Limit Select
S5	
S6	
S7	Battery Type Select
S8	
S9	Charger Current Select
S10	
S11	DC Source on/off
S12	Saving Function on/off

Output Voltage switch Function (S1,S2)

Output Voltage	S1	S2
100V / 200V	OFF	OFF
110V / 220V	ON	OFF
115V / 230V	OFF	ON
120V / 240V	ON	ON

Output Frequency switch Function (S3)

Frequency	S3
50HZ	OFF
60HZ	ON

AC Input Current Limit Select (S4,S5,S6)

AC Input Current 100~120V / 200~240V	S4	S5	S6
3A / 2A	OFF	OFF	OFF
6A / 4A	ON	OFF	OFF
9A / 6A	OFF	ON	OFF
12A / 8A	ON	ON	OFF
15A / 10A	OFF	OFF	ON
20A / 12A	ON	OFF	ON
25A / 14A	OFF	ON	ON
30A / 16A	ON	ON	ON

Battery Type Select Function (S7,S8) :

Battery Type	S7	S8
GEL	OFF	OFF
Flooded	ON	OFF
AGM	OFF	ON
Customer	ON	ON

Battery Type	Bulk	Absorption	Float
GEL	14.40V	14.10V	13.60V
Flooded	14.70V	14.60V	13.40V
AGM	14.70V	14.30V	13.10V
Customer	14.70V	14.50V	13.50V

Charger Current Select Function (S9,S10)

Charger Current	S9	S10
25%	OFF	OFF
50%	ON	OFF
75%	OFF	ON
100%	ON	ON

DC Source Output On/Off Function (S11)

ESB function	S11
OFF	OFF
ON	ON

Saving Function Switch ON/OFF Function (S12)

Saving function	S12
OFF	OFF
ON	ON

Power Saving Load Function

	Saving Wake up Power	Input Saving Mode Power
SC-1200	> 40 VA	> 20 VA
SC-2000	> 40 VA	> 20 VA

■ Rear panel

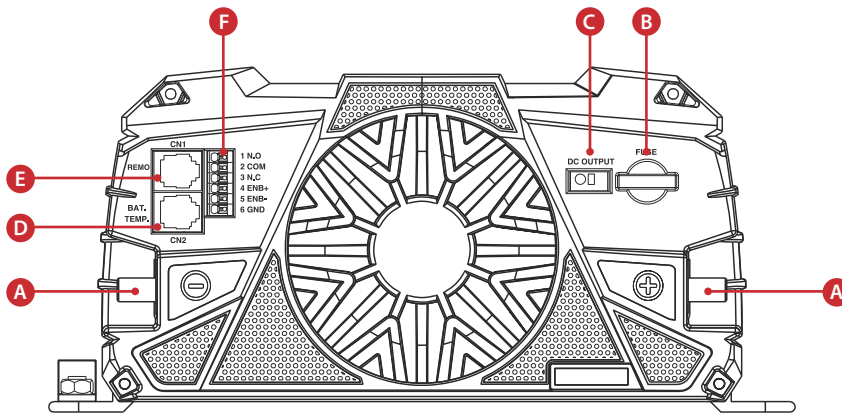

- (A) DC input connector
- (B) Auxiliary DC output Fuse
- (C) Auxiliary DC output
- (D) BAT TEMP Port (RJ11)
- (E) Remote port (RJ11)
- (F) Remote control terminal

■ BAT. TEMP. Port (RJ-11)



Pin Number	Signal Description
1	Not used
2	GND
3	Batteries temperature sensor
4	Battery Detect
5	Not used
6	Not used

■ Remote Port (RJ-11)

Pin Number	Signal Description	
1	Reserved	--
2	GND	The same polarity as the battery negative side
3	RXD	RS232 RXD
4	TXD	RS232 TXD
5	RMT	Remote controller panel (positive)
6	VCC	Internal power for remote controller

Remote Control & Green Terminal

Remote control green terminal may be connected to a Form C relay for "FAULT" indication. When "FAULT" occurs, the relay switches.

Remote control terminal

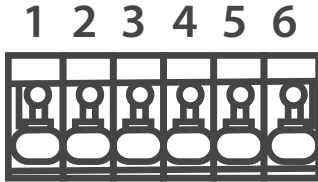

Item	Description	Item	Description
1	Dry contact (Normal Open)	4	Enable+ (ENB)
2	Common	5	Enable- (ENB)
3	Dry contact (Normal Closed)	6	Ground

Dry contact terminal definition

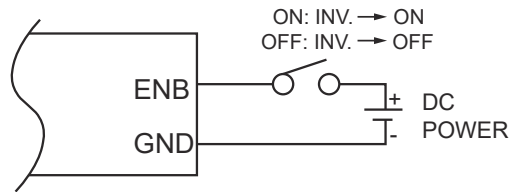
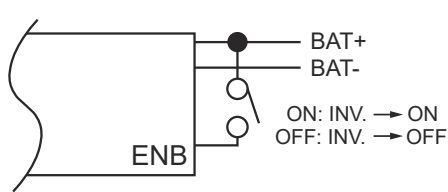
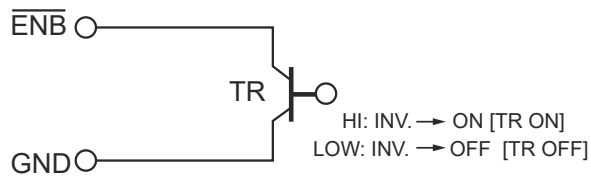
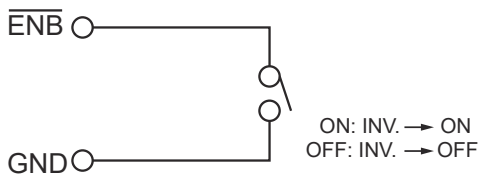

Specifications of the Relay

Maximum Voltage	Load	Contact Rating		Number of operations	Operating/Storage Temperature
		N.O	N.C		
250 VAC	Resistive	1 A	---	100,000	-30°C~75°C
250 VAC	Resistive	---	1 A	---	
24 VDC	Resistive	1 A	---	---	
24 VDC	Resistive	---	1 A	---	